

# AUTOTUNE

## INSTALLATION GUIDE

THIS GUIDE COVERS AUTO TUNE FOR POWER VISION  
PART NUMBERS: AT110/AT-110B AND AT120/120B

### PARTS LIST

1- Auto Tune module	1- 52" O2 Sensor Cable	2- O2 Sensor Bungs
1- Installation Guide	1- 24" O2 Sensor Cable	
1- 72" Can to Can Cable	3 - 8" Cable Ties	
1- Y-Adapter Cable	2- Dual Lock Velcro	
2- 18mm O2 Sensors	1- Alcohol swab	



#### O2 SENSOR BUNGS



INCLUDED WITH  
AUTO TUNE AT-110B  
AND AT-120B KITS

## !!! IMPORTANT PLEASE READ FIRST !!!

This kit is designed to be used exclusively with the Dynojet Power Vision. The Auto Tune module by itself does not tune your vehicle; rather it transmits wide band Air-Fuel Ratio (AFR), or more precisely, Lambda values to the Power Vision. This data is critical to determine exactly how rich, or how lean your vehicle is running. Unlike narrow band oxygen sensors, the Bosch wide band sensors included in this Auto Tune kit are extremely accurate at all operating ranges of your vehicle.

To use the AutoTune Pro module to modify your tune, you need to run AutoTune Pro sessions on your Power Vision. This will create a new tune, based off an existing tune, using feedback from the AutoTune Pro module. We recommend AutoTune sessions of approximately 20 minutes each.

SOFTWARE AND OTHER TECHNICAL INFORMATION ARE AVAILABLE ONLINE AT:

**WWW.FLASHYOURHARLEY.COM.**

The Auto Tune module requires the use of (2) 18mm O2 sensors. If your bike's exhaust system doesn't have bungs pre-installed, bungs will have to be welded into the header pipes to use this module. Please refer to page 3 for bung installation.

1. Locate the diagnostics port on your motorcycle. This may require the removal of the seat and some body panels.

**Note:** The location of the diagnostic port varies depending on model, so please refer to a service manual or contact Dynojet for the exact location.

**USE CAUTION:** Many models use the same style connector for accessories. Your Power Vision **MUST** be connected to the diagnostic port.

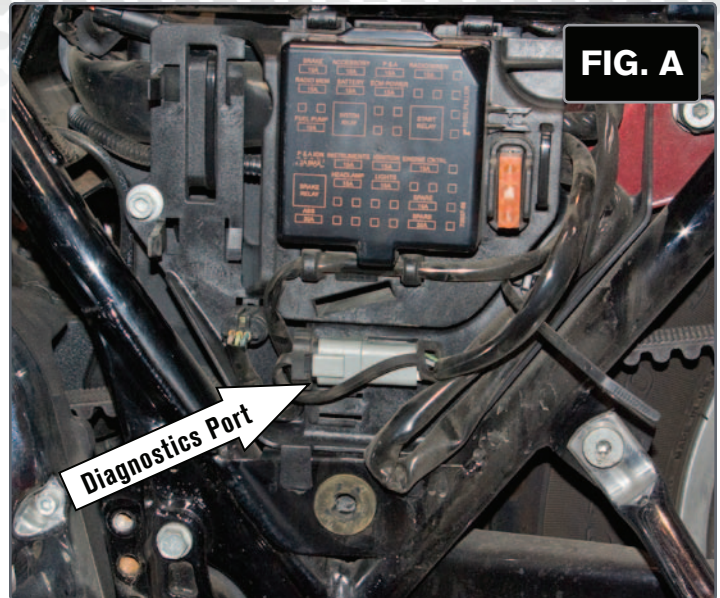

2. Locate a secure location to mount the Auto Tune module. On most models the module can be mounted under the seat or under a side cover.

**Note:** Keep module and wiring away from moving parts to prevent damage.

3. Install both O2 sensors into the exhaust system. First connect the long O2 sensor harness to the front O2 sensor and route harness along the frame.

Next connect the short O2 sensor harness to the rear O2 sensor and route harness along the frame.

**Note:** Keep harness away from HOT and moving parts to prevent damage. **See Fig. B**

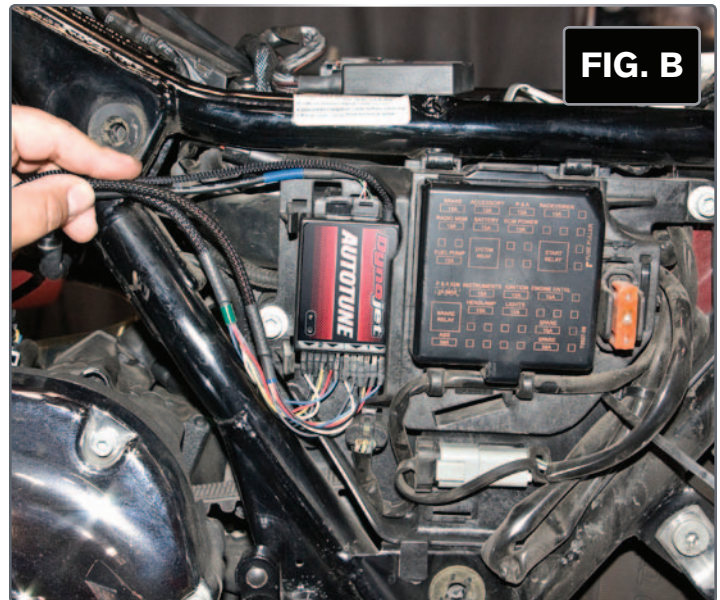

4. Connect the front O2 sensor harness to Auto Tune module input #1 per Fig. C.

Connect the rear O2 sensor harness to Auto Tune module input #2 per Fig. C.

**Note:** The harness can be cut to length if desired.

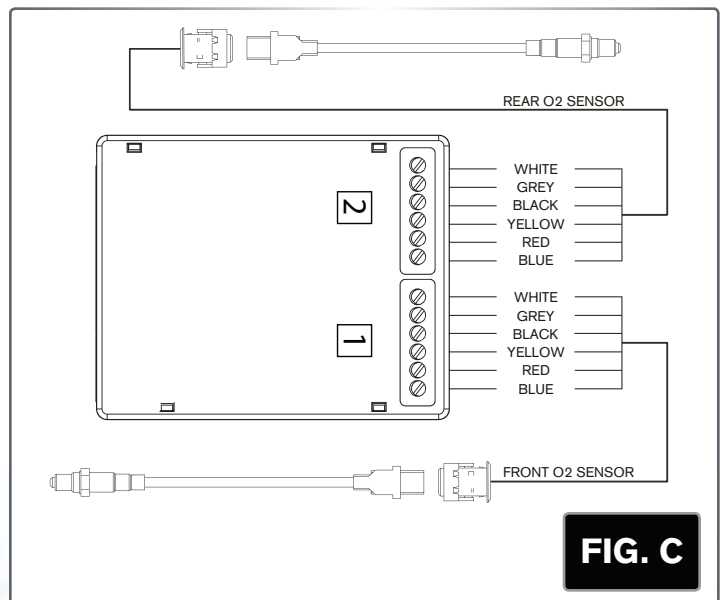

5. Connect the Supplied Y-Adaptor to the Diagnostics port on the motorcycle.

Route and connect the power lead from the Auto Tune module to one side of the Y-adaptor.

Connect the Power Vision to the unused side of the Y-adaptor.

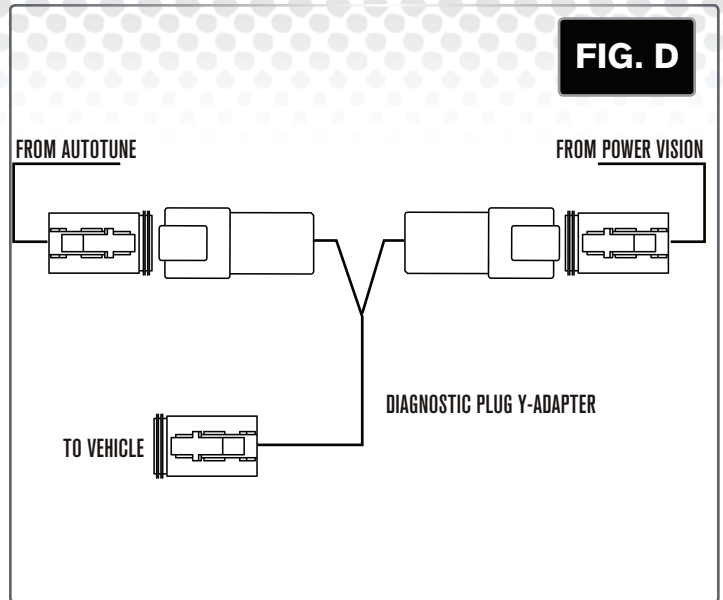

6. Connect the CAN bus link cable to the Auto Tune module. Route cable to the Power Vision and secure.
7. Secure the Auto Tune Module with the supplied Velcro.
8. Secure any remaining sections of the wiring for the Auto Tune module and verify wiring is free and clear of abrasion and heat sources.

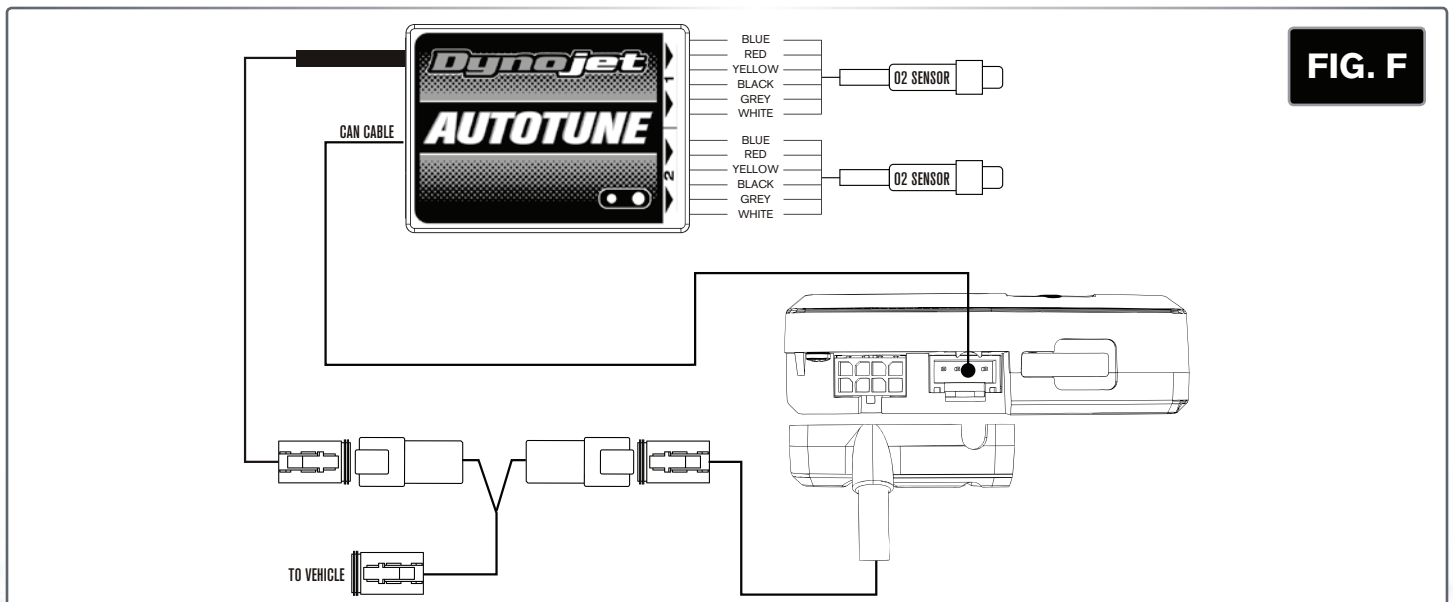
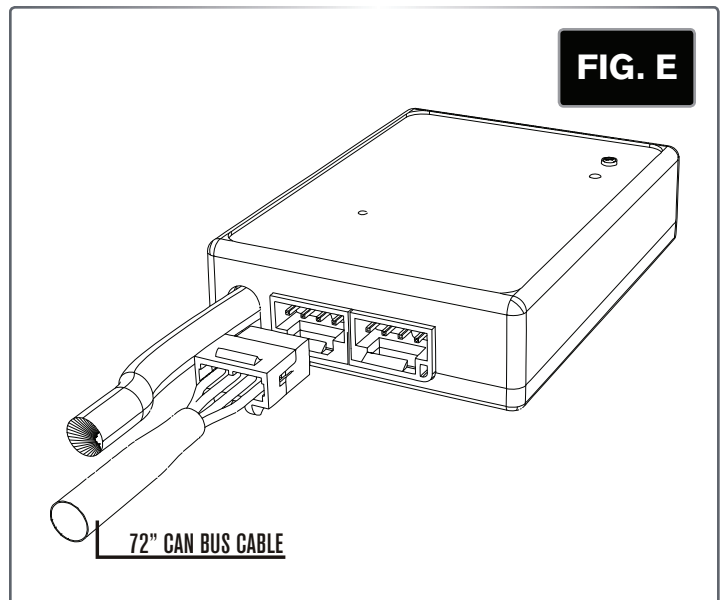



## O2 SENSOR BUNG INSTALLATION

1. Find a suitable location to install the included M18 x 1.5mm bungs on the exhaust system.

**Note:** Suitable locations may vary depending on exhaust system. (See Fig. A and B)

2. Mount the bungs in a manner that reduces the risk of moisture contamination to the sensor, as condensation can build up in the exhaust system. Ideally, the sensor should be between the 9 o'clock and 3 o'clock position on the pipe. A 10° incline of the sensor should be considered a minimum. (See Fig. C)

3. Mark the pipe where bungs will be mounted.

**Note:** Adequate room will be needed for the sensor body and wiring.

4. Remove the exhaust system.
5. Drilling and welding of the exhaust system should be done by a professional.
6. Reinstall the exhaust system.

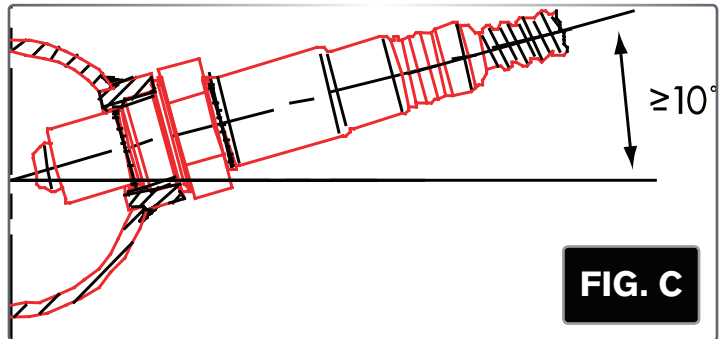
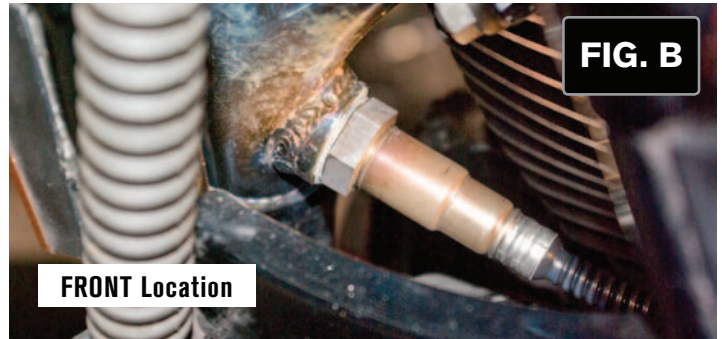
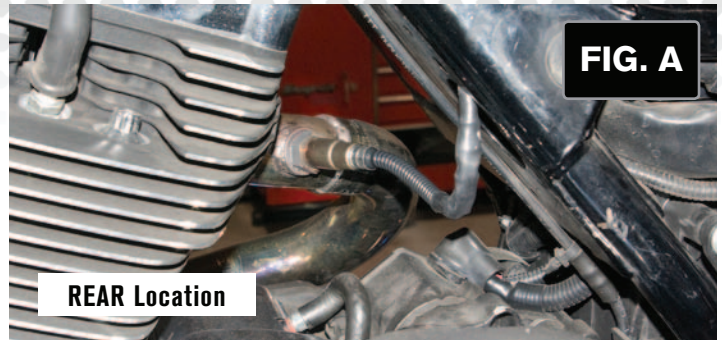

## O2 SENSOR TEST

1. The Auto Tune kit has a built in circuit which allows you to test the sensor accuracy and condition.
2. Remove the sensor from the exhaust system and hold in ambient air.
3. Verify the Auto Tune kit has been powered up for at least 1 minute.
4. Press and hold the function button on the front of the corresponding Auto Tune kit for 3 seconds and release the button.
5. The LED light will blink rapidly, pause for a moment, and then begin to flash.
6. Count the number of flashes and refer to the chart.
7. Retest the sensor if there is any question as to the purity of the air during the test.

