

[POWER COMMANDER V]

2015 Ducati Multistrada 1200

Installation Instructions



PARTS LIST

- 1 Power Commander
- 1 USB Cable
- 1 Installation Guide
- 2 Power Commander Decals
- 2 Dynojet Decals
- 2 Velcro strips
- 1 Alcohol swab
- 2 Posi-taps

THE IGNITION MUST BE TURNED OFF BEFORE INSTALLATION!

THE LATEST POWER COMMANDER SOFTWARE AND MAP FILES CAN BE DOWNLOADED FROM OUR WEB SITE AT:
www.powercommander.com

PLEASE READ ALL DIRECTIONS BEFORE STARTING INSTALLATION

Dynojet

2191 Mendenhall Drive North Las Vegas, NV 89081 (800) 992-4993 www.powercommander.com

POWER COMMANDER V INPUT ACCESSORY GUIDE

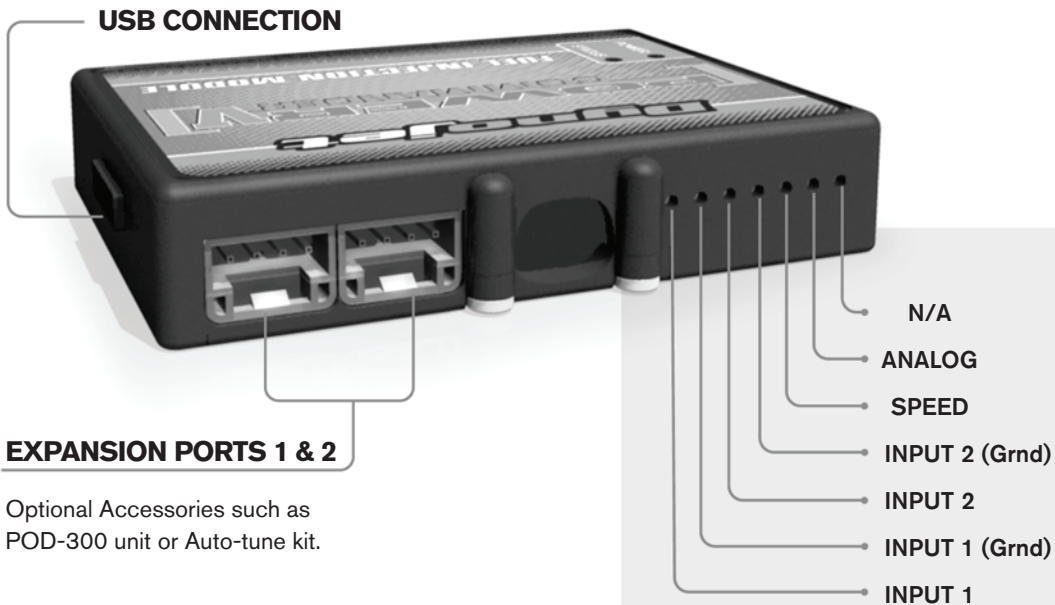

Wire connections:

To input wires into the PCV first remove the rubber plug on the backside of the unit and loosen the screw for the corresponding input. Using a 22-24 gauge wire strip about 10mm from its end. Push the wire into the hole of the PCV until it stops and then tighten the screw. Make sure to reinstall the rubber plug.

NOTE: If you tin the wires with solder it will make inserting them easier.

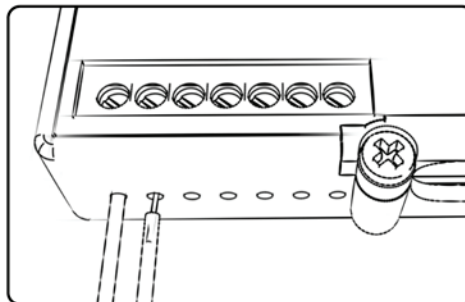

ACCESSORY INPUTS

Map -

(Input 1 or 2) The PCV has the ability to hold 2 different base maps. You can switch on the fly between these two base maps when you hook up a switch to the MAP inputs. You can use any open/close type switch. The polarity of the wires is not important. When using the Autotune kit one position will hold a base map and the other position will let you activate the learning mode. When the switch is "CLOSED" Autotune will be activated. (Set to Switch Input #1 by default.)

Shifter-

(Input 1 or 2) These inputs are for use with the Dynojet quickshifter. Insert the wires from the Dynojet quickshifter into the SHIFTER inputs. The polarity of the wires is not important. (Set to Switch Input #2 by default.)

Speed-

If your application has a speed sensor then you can tap into the signal side of the sensor and run a wire into this input. This will allow you to calculate gear position in the Control Center Software. Once gear position is setup you can alter your map based on gear position and setup gear dependent kill times when using a quickshifter.

Analog-

This input is for a 0-5v signal such as engine temp, boost, etc. Once this input is established you can alter your fuel curve based on this input in the control center software.

Crank-

Do **NOT** connect anything to this port unless instructed to do so by Dynojet. It is used to transfer crank trigger data from one module to another.

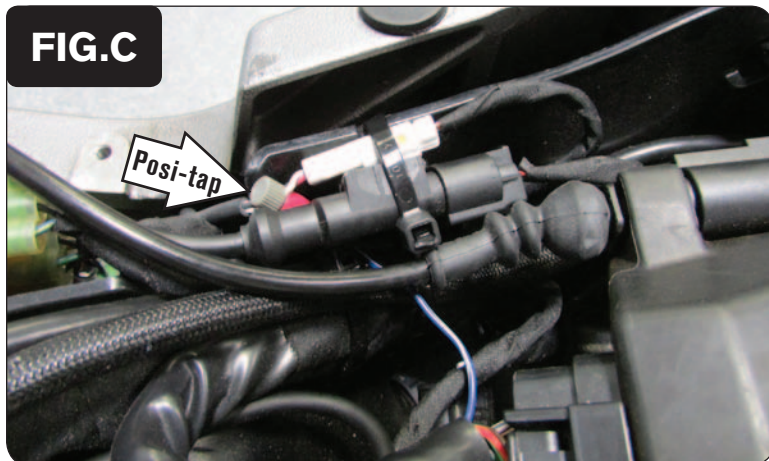
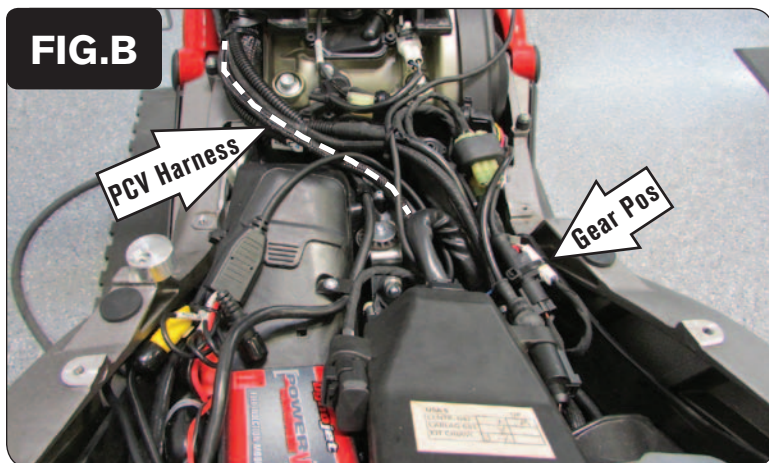

1 Remove the seats, side panels, and all of the bodywork surrounding the fuel tank (Fig. A).

2 Loosen the fuel tank. Lift and prop the rear of the fuel tank.

3 Secure the PCV module to the top of the battery with the supplied Velcro. Clean surfaces with the supplied alcohol swab prior to applying the Velcro.

4 Route the PCV harness towards the engine. Go beneath the stock electronics and alongside the stock wiring. Try to keep the harness as low as possible. Space is limited on this model.

5 Locate the WHITE 3-pin Gear Position sensor connector on the right side of the bike.

6 Using the supplied Posi-tap, attach the single unterminated BLUE/WHITE wire from the PCV to the stock WHITE wire on the Gear Position sensor connector.

This gear position analog voltage signal input is optional.

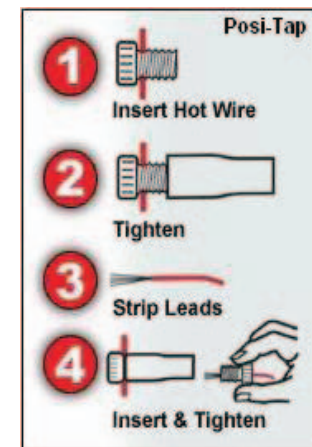

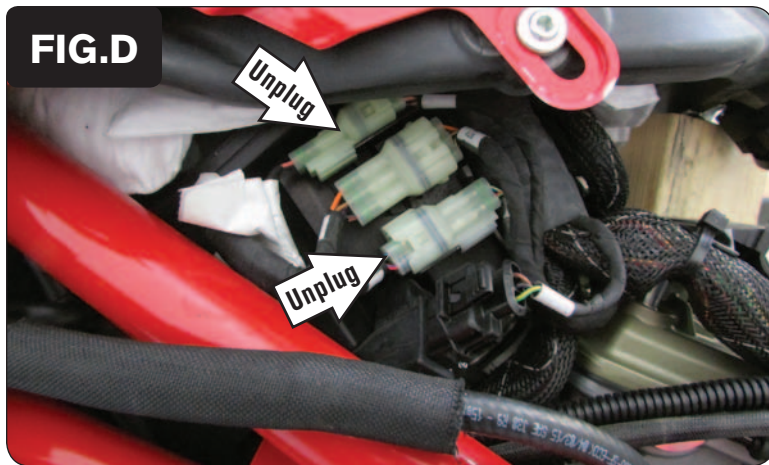

- 7 Beneath the rear of the fuel tank on the left side of the bike, locate and unplug the stock Fuel Injector connector and the stock Throttle Body Servo connector for the Vertical cylinder.

The Fuel Injector connector is a CLEAR 3-pin connector that is marked "INJ."

The Throttle Body Servo connector for the Vertical cylinder is a CLEAR 6-pin connector that is marked "ETV V." It is NOT the one marked "ETV H."



- 8 Plug the PCV wiring harness in-line of the stock "INJ" and "ETV V" connectors (Fig. E).
- 9 Store the extra connectors under the fuel tank as close to the original location as possible. Route the remaining branch of the PCV wiring harness downward, towards the left side of the engine. Keep the wiring inside of the frame.



- 10 Locate and unplug the stock Crank Position Sensor connectors on the left side of the engine (Fig. F).



11 Plug the PCV wiring harness in-line of the stock Crank Position Sensor connectors (Fig. G).

12 Use the remaining Posi-tap to attach the single unterminated GREY/WHITE wire of the PCV to the stock GREEN/WHITE wire of the bike's Engine Temperature Sensor connector.

This connector is located inside the frame rail on the left side of the bike, just above the stock Crank Position Sensor connectors (Fig. H).

This engine temperature analog voltage signal input is optional.

13 Secure the PCV ground wire with the small ring terminal to the left side engine cover bolt shown in Figure J.

14 Reinstall the fuel tank, all of the bodywork, and the seats.

Tuning Notes:

This bike uses a fly-by wire system, so conventional tuning can not be performed for all RPM and throttle ranges.

The throttle position input for the PCV is attached to the throttle blade angle sensor of the throttle bodies which is NOT directly correlated to the throttle grip position. Because of this when setting the throttle position in the PCV software we recommend on resetting only the closed position after the bike has completely warmed up. Use the arrow key (<) next to CLOSED to perform this step and then click OK. Do not try to set the OPEN position.

The stock fuel curve can not be adjusted at 5-20% throttle up to 6250 RPM. This is where the stock ECU goes into closed loop.

