

[POWER COMMANDER V]

2000-2001 Honda CBR929RR

Installation Instructions



PARTS LIST

- 1 Power Commander
- 1 USB Cable
- 1 Installation Guide
- 2 Power Commander Decals
- 2 Dynojet Decals
- 2 Velcro strips
- 1 Alcohol swab

**THE IGNITION MUST BE TURNED
OFF BEFORE INSTALLATION!**

THE LATEST POWER COMMANDER
SOFTWARE AND MAP FILES CAN BE
DOWNLOADED FROM OUR WEB SITE AT:
www.powercommander.com

PLEASE READ ALL DIRECTIONS BEFORE STARTING INSTALLATION

Dynojet

2191 Mendenhall Drive North Las Vegas, NV 89081 (800) 992-4993 www.powercommander.com

POWER COMMANDER V INPUT ACCESSORY GUIDE

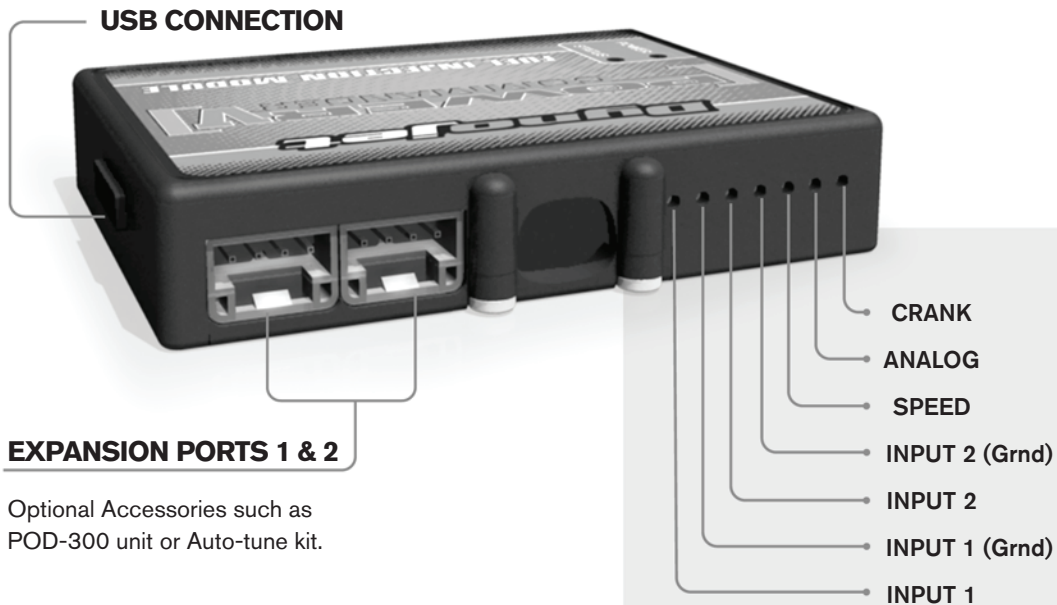

Wire connections:

To input wires into the PCV first remove the rubber plug on the backside of the unit and loosen the screw for the corresponding input. Using a 22-24 gauge wire strip about 10mm from its end. Push the wire into the hole of the PCV until it stops and then tighten the screw. Make sure to reinstall the rubber plug.

NOTE: If you tin the wires with solder it will make inserting them easier.

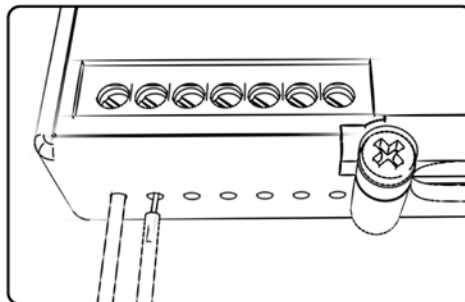

ACCESSORY INPUTS

Map -

(Input 1 or 2) The PCV has the ability to hold 2 different base maps. You can switch on the fly between these two base maps when you hook up a switch to the MAP inputs. You can use any open/close type switch. The polarity of the wires is not important. When using the Autotune kit one position will hold a base map and the other position will let you activate the learning mode. When the switch is "CLOSED" Autotune will be activated. (Set to Switch Input #1 by default.)

Shifter-

(Input 1 or 2) These inputs are for use with the Dynojet quickshifter. Insert the wires from the Dynojet quickshifter into the SHIFTER inputs. The polarity of the wires is not important. (Set to Switch Input #2 by default.)

Speed-

If your application has a speed sensor then you can tap into the signal side of the sensor and run a wire into this input. This will allow you to calculate gear position in the Control Center Software. Once gear position is setup you can alter your map based on gear position and setup gear dependent kill times when using a quickshifter.

Analog-

This input is for a 0-5v signal such as engine temp, boost, etc. Once this input is established you can alter your fuel curve based on this input in the control center software.

Crank-

Do **NOT** connect anything to this port unless instructed to do so by Dynojet. It is used to transfer crank trigger data from one module to another.

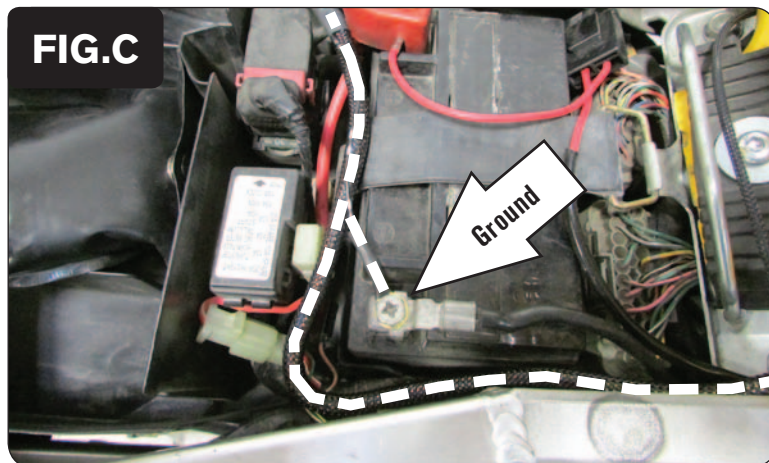
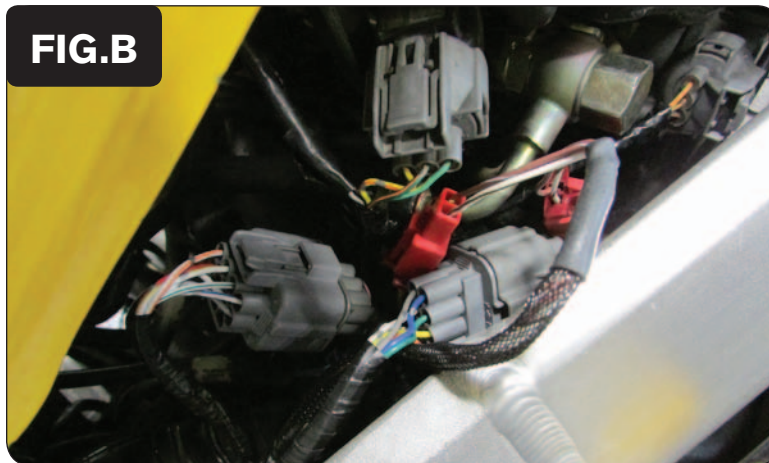
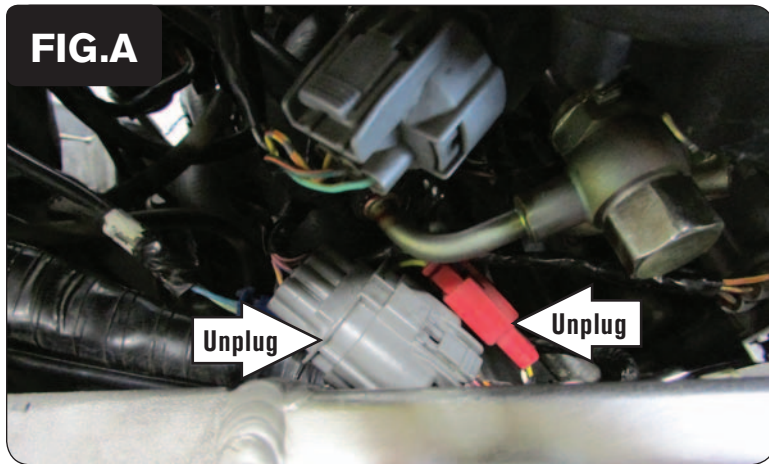

- 1 Remove the main seat and the passenger seat.
- 2 Remove the fuel tank mounting bolts at the front of the fuel tank and prop the front of the fuel tank up.
The fuel tank does not need to be removed in order to install the PCV. If you choose to remove the fuel tank to aid in the installation, then all fuel will need to be drained from the tank prior to disconnecting the fuel lines.
- 3 Locate and unplug the fuel injector sub-harness connector and the crank position sensor connector (Fig. A).
The fuel injector sub-harness connector is a GREY 8-pin connector. The Crank Position Sensor connector is a RED 2-pin connector. Both are on the right side of the bike just under the fuel hose fitting on the throttle bodies.
- 4 Plug the 2 pairs of connectors of the PCV wiring harness in-line of the 2 pairs of stock connectors (Fig. B).
- 5 Route the PCV wiring harness under the fuel tank and towards the tail section.
- 6 Lower the fuel tank making sure not to pinch the PCV wiring harness and resecure the front of the fuel tank with the mounting bolts.
- 7 Secure the PCV ground wire with the ring lug to the negative (-) terminal of the bike's battery (Fig. C).

FIG.D



- 8 Route the PCV and wiring harness under the rear seat subframe.
- 9 Use the supplied Velcro to secure the PCV module in the tail section to the inner fender below the passenger seat (Fig. D).

Clean the surface area with the supplied alcohol swab prior to applying the Velcro.

- 10 Reinstall the seats.

Optional inputs:

Speed - PINK wire of speed sensor. This can be found on a BLACK 3-pin connector under the fuel tank. This connector has PINK, GREEN, and BLACK wires.

Temperature - PINK/WHITE wire of coolant temperature sensor. This sensor is on the thermostat housing at the rear of the engine. This sensor has PINK/WHITE, GREEN/ORANGE, and GREEN/BLUE wires.

12v source for Auto-tune - BROWN/BLUE wire from tail lights.