

[POWER COMMANDER V]

2010-2014 Kawasaki ZG1400

Installation Instructions



PARTS LIST

- 1 Power Commander
- 1 USB Cable
- 1 Installation Guide
- 2 Power Commander Decals
- 2 Dynojet Decals
- 2 Velcro strips
- 1 Alcohol swab

**THE IGNITION MUST BE TURNED
OFF BEFORE INSTALLATION!**

THE LATEST POWER COMMANDER
SOFTWARE AND MAP FILES CAN BE
DOWNLOADED FROM OUR WEB SITE AT:
www.powercommander.com

PLEASE READ ALL DIRECTIONS BEFORE STARTING INSTALLATION

Dynojet

2191 Mendenhall Drive North Las Vegas, NV 89081 (800) 992-4993 www.powercommander.com

POWER COMMANDER V INPUT ACCESSORY GUIDE

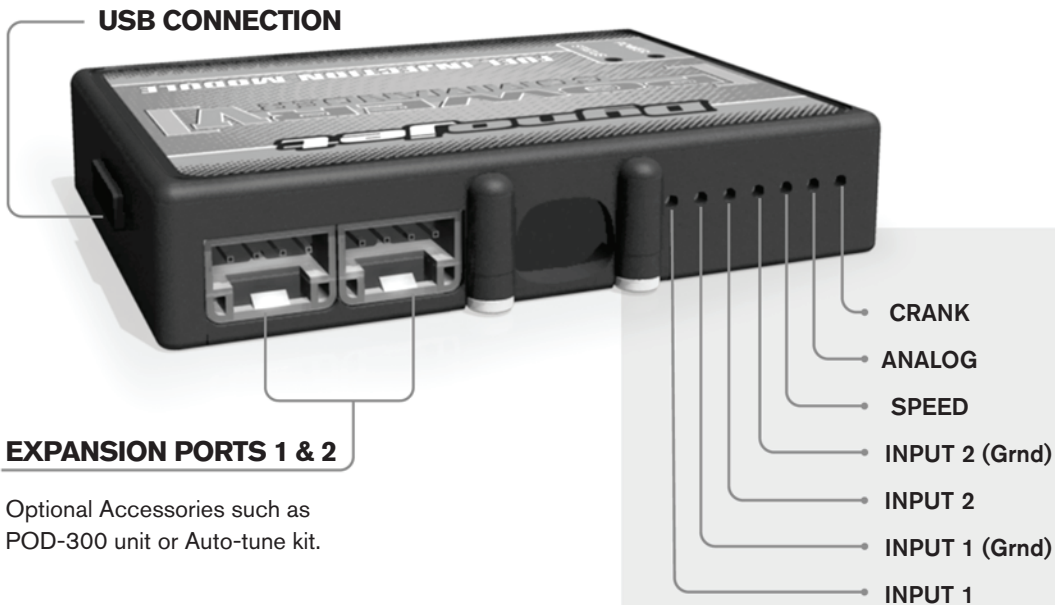

Wire connections:

To input wires into the PCV first remove the rubber plug on the backside of the unit and loosen the screw for the corresponding input. Using a 22-24 gauge wire strip about 10mm from its end. Push the wire into the hole of the PCV until it stops and then tighten the screw. Make sure to reinstall the rubber plug.

NOTE: If you tin the wires with solder it will make inserting them easier.

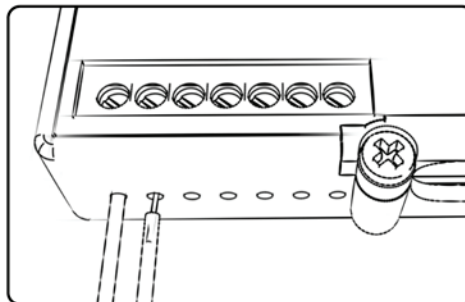

ACCESSORY INPUTS

Map -

(Input 1 or 2) The PCV has the ability to hold 2 different base maps. You can switch on the fly between these two base maps when you hook up a switch to the MAP inputs. You can use any open/close type switch. The polarity of the wires is not important. When using the Autotune kit one position will hold a base map and the other position will let you activate the learning mode. When the switch is "CLOSED" Autotune will be activated. (Set to Switch Input #1 by default.)

Shifter-

(Input 1 or 2) These inputs are for use with the Dynojet quickshifter. Insert the wires from the Dynojet quickshifter into the SHIFTER inputs. The polarity of the wires is not important. (Set to Switch Input #2 by default.)

Speed-

If your application has a speed sensor then you can tap into the signal side of the sensor and run a wire into this input. This will allow you to calculate gear position in the Control Center Software. Once gear position is setup you can alter your map based on gear position and setup gear dependent kill times when using a quickshifter.

Analog-

This input is for a 0-5v signal such as engine temp, boost, etc. Once this input is established you can alter your fuel curve based on this input in the control center software.

Crank-

Do **NOT** connect anything to this port unless instructed to do so by Dynojet. It is used to transfer crank trigger data from one module to another.



- 1 Remove the left hand fairing and inner fairing panel.
- 2 Remove the cover on the top of the fuel tank (Fig. A).

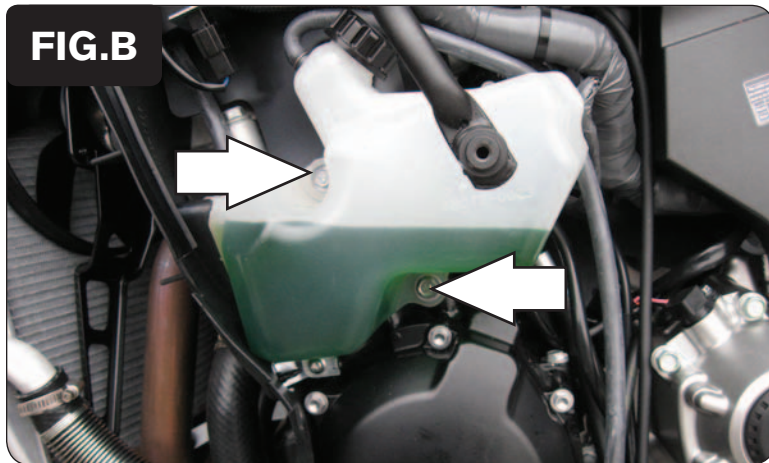

- 3 Remove the coolant reserve bottle by removing the two mounting bolts. (Fig. B).

You do not need to disconnect the hoses. Just move the bottle out of the way for easier access to the wiring harness.

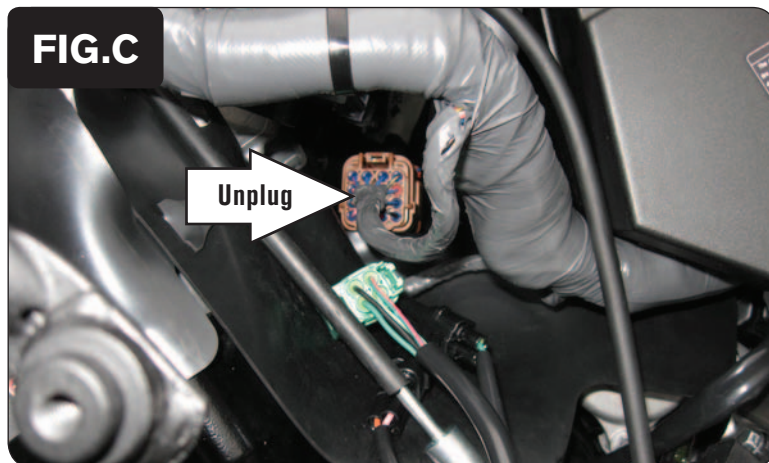

- 4 Unplug the stock wiring harness from the throttle bodies (Fig. C).

This is a 16-pin BROWN connector pair.

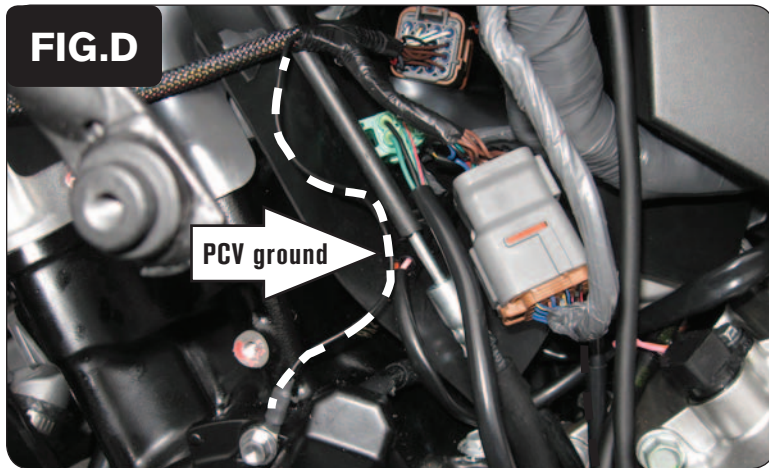

- 5 Plug the PCV harness in-line of the stock wiring harness and throttle bodies. (Fig. D).
- 6 Attach the ground wire from the PCV to the engine case bolt (Fig. D).
- 7 Reinstall the coolant bottle.

- 8 Using the supplied Velcro secure the PCV to the relay bracket (Fig. E).
Use the supplied alcohol swab to clean both surfaces prior to applying the Velcro.
- 9 Reinstall the bodywork.

Note: If using the software to reset the throttle position make sure the bike up to full operating temperature before doing so.

Optional inputs:

Speed - PINK wire on speed sensor. Located on left side of engine near output shaft.

12v source for Auto-tune - RED/BLUE wire of tail light. Use wire going to fuse box.