

[POWER COMMANDER V]

FUEL AND IGNITION
2012-2014 Kawasaki
EX650 / ER6n / Versys 650

Installation Instructions



PARTS LIST

- 1 Power Commander
- 1 USB Cable
- 1 Installation Guide
- 2 Power Commander Decals
- 2 Dynojet Decals
- 2 Velcro strips
- 1 Alcohol swab

**THE IGNITION MUST BE TURNED
OFF BEFORE INSTALLATION!**

THE LATEST POWER COMMANDER
SOFTWARE AND MAP FILES CAN BE
DOWNLOADED FROM OUR WEB SITE AT:
www.powercommander.com

PLEASE READ ALL DIRECTIONS BEFORE STARTING INSTALLATION

Dynojet

2191 Mendenhall Drive North Las Vegas, NV 89081 (800) 992-4993 www.powercommander.com

POWER COMMANDER V INPUT ACCESSORY GUIDE

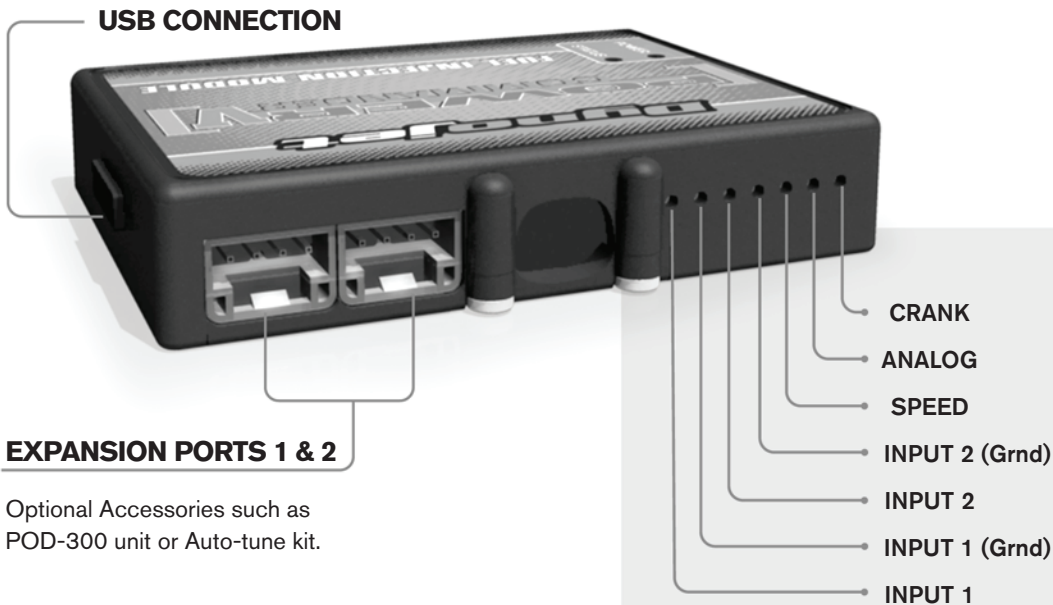

Wire connections:

To input wires into the PCV first remove the rubber plug on the backside of the unit and loosen the screw for the corresponding input. Using a 22-24 gauge wire strip about 10mm from its end. Push the wire into the hole of the PCV until it stops and then tighten the screw. Make sure to reinstall the rubber plug.

NOTE: If you tin the wires with solder it will make inserting them easier.

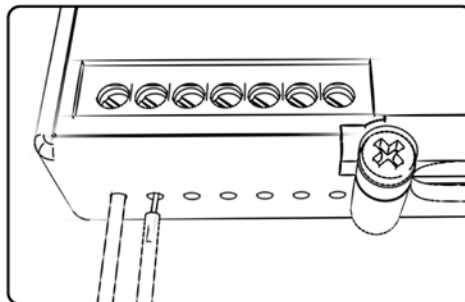

ACCESSORY INPUTS

Map -

(Input 1 or 2) The PCV has the ability to hold 2 different base maps. You can switch on the fly between these two base maps when you hook up a switch to the MAP inputs. You can use any open/close type switch. The polarity of the wires is not important. When using the Autotune kit one position will hold a base map and the other position will let you activate the learning mode. When the switch is "CLOSED" Autotune will be activated. (Set to Switch Input #1 by default.)

Shifter-

(Input 1 or 2) These inputs are for use with the Dynojet quickshifter. Insert the wires from the Dynojet quickshifter into the SHIFTER inputs. The polarity of the wires is not important. (Set to Switch Input #2 by default.)

Speed-

If your application has a speed sensor then you can tap into the signal side of the sensor and run a wire into this input. This will allow you to calculate gear position in the Control Center Software. Once gear position is setup you can alter your map based on gear position and setup gear dependent kill times when using a quickshifter.

Analog-

This input is for a 0-5v signal such as engine temp, boost, etc. Once this input is established you can alter your fuel curve based on this input in the control center software.

Crank-

Do **NOT** connect anything to this port unless instructed to do so by Dynojet. It is used to transfer crank trigger data from one module to another.

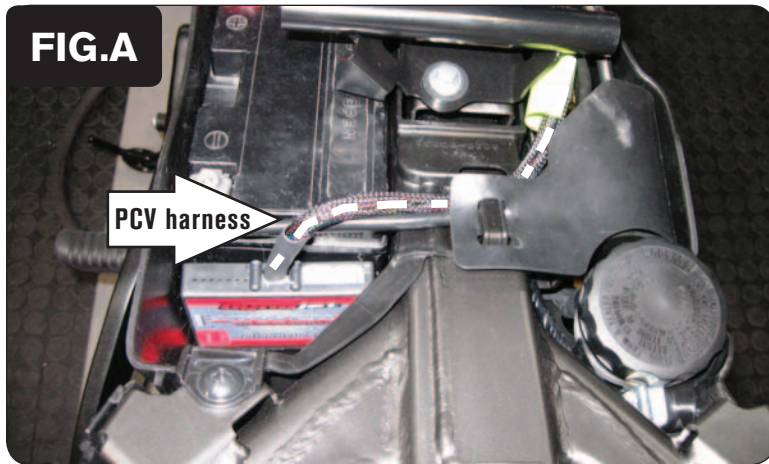

- 1 Remove the plastic cover at the front of the fuel tank, the seat, the fuel tank, the airbox, the left side mid-fairing, and the two plastic side covers that are rear of the mid fairings and covering the footpeg brackets.

There is a single allen bolt clamping the airbox to the throttle bodies that can be accessed from the left side of the bike.

- 2 Use the supplied alcohol swab and velcro to secure the PCV module in the battery compartment to the rear of the battery (Fig. A).

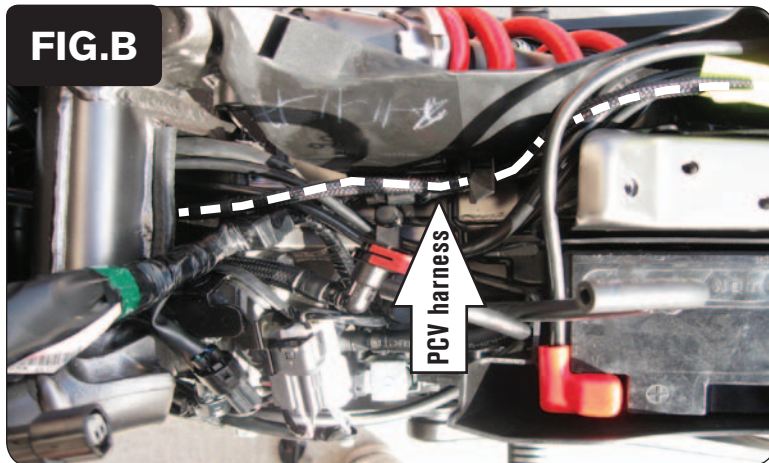

- 3 Route the PCV harness along side the factory wiring on the right hand side of the bike, through the hole in the center of the frame, and up towards the throttle bodies (Fig. B).

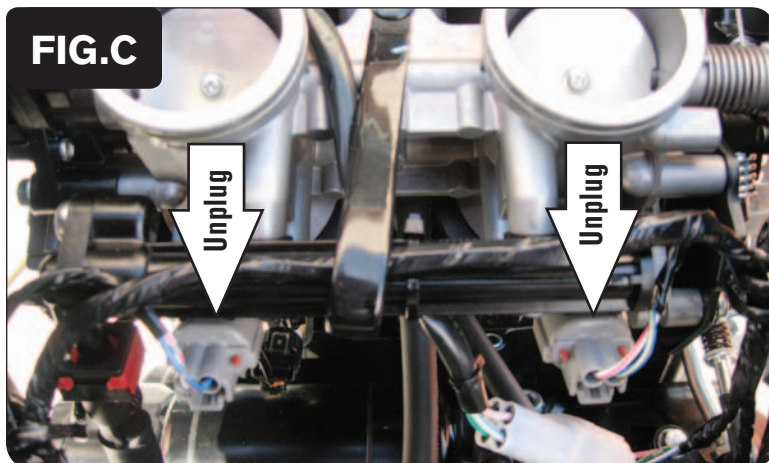

- 4 Unplug the stock wiring harness from the fuel injectors (Fig. C).

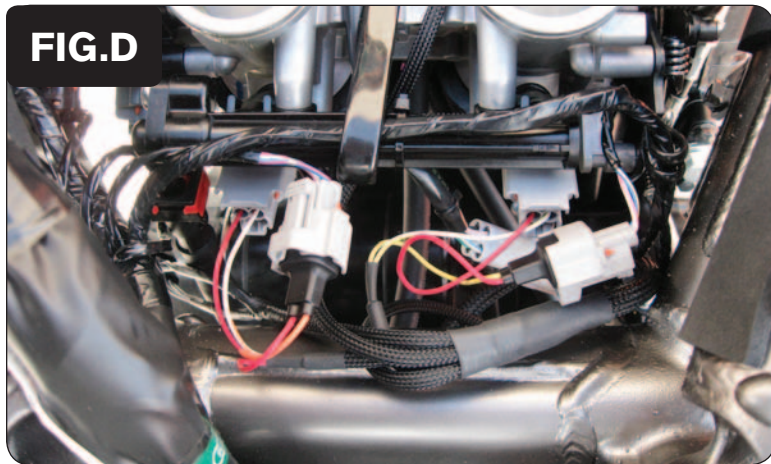

- 5 Plug the PCV connectors in-line of the stock wiring harness and fuel injector for both cylinders (Fig. D).

Plug the PCV connectors with ORANGE colored wires to the left cylinder.

Plug the PCV connectors with YELLOW colored wires to the right cylinder.

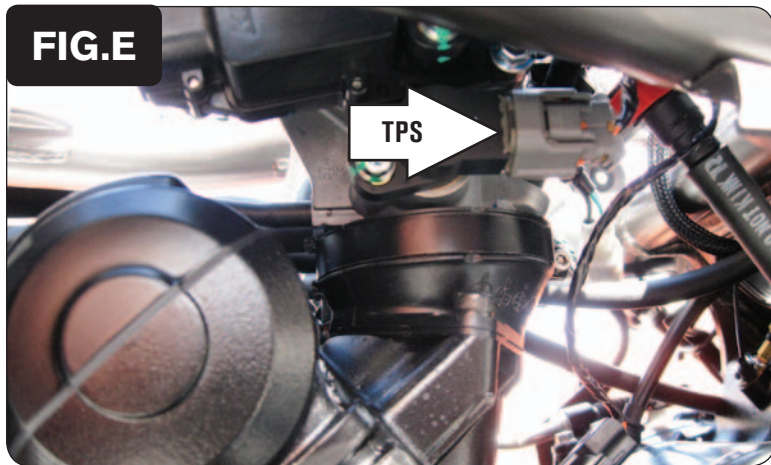

- 6 Locate and unplug the stock wiring harness from the Throttle Position Sensor on the left hand side of the bike's throttle bodies (Fig. E).

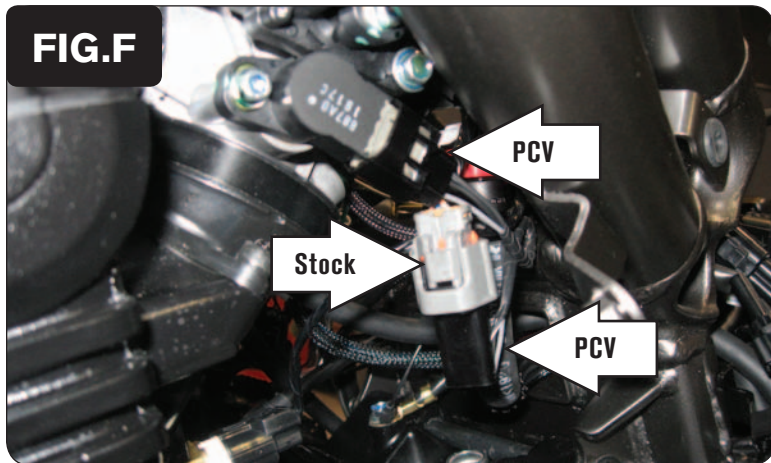

- 7 Plug the PCV wiring harness in-line of the stock wiring harness and the TPS (Fig. F).

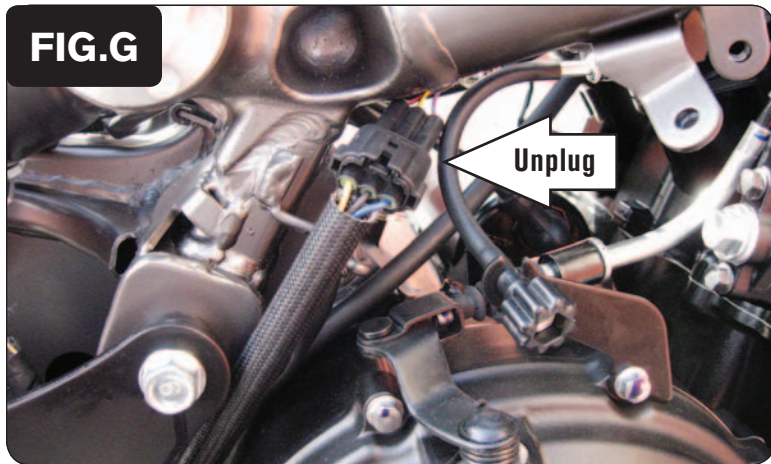

- 8 Locate and unplug the bike's Crank Position Sensor connectors on the right-hand side of the bike (Fig. G).

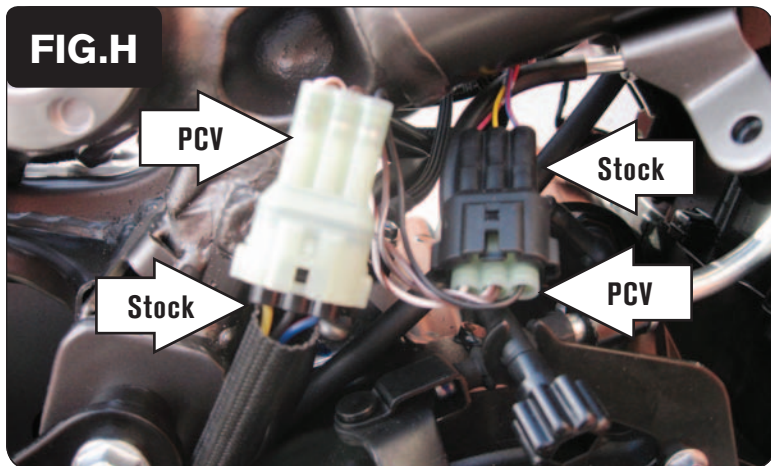

- 9 Plug the PCV connectors in-line of the stock Crank Position Sensor connectors (Fig. H).

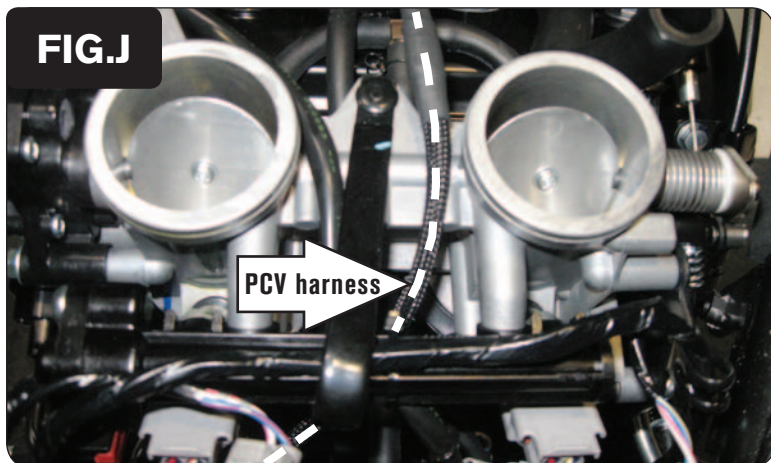

- 10 Route the remainder of the PCV wiring harness with the coil connectors under the fuel rail, in between the throttle bodies, and up towards the coil sticks (Fig. J).

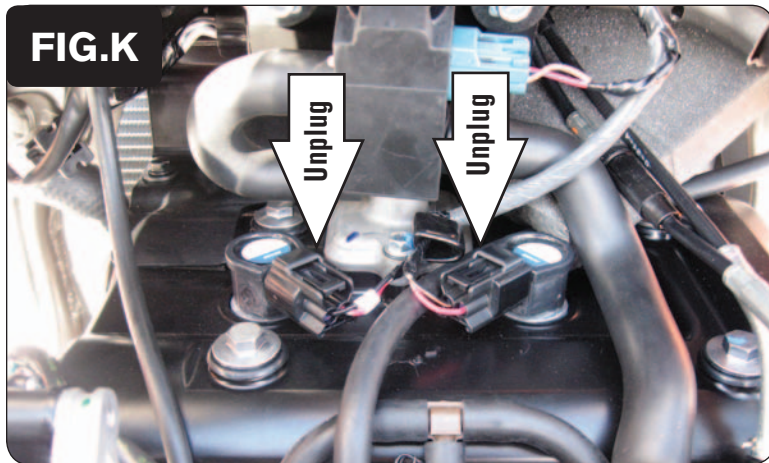

11 Unplug the stock wiring harness from the coil sticks (Fig. K).



12 Plug the PCV wiring harness in-line of the stock wiring harness and the coil sticks (Fig. L).

Plug the PCV connectors with GREEN colored wires to the left cylinder.

Plug the PCV connectors with BLUE colored wires to the right cylinder.

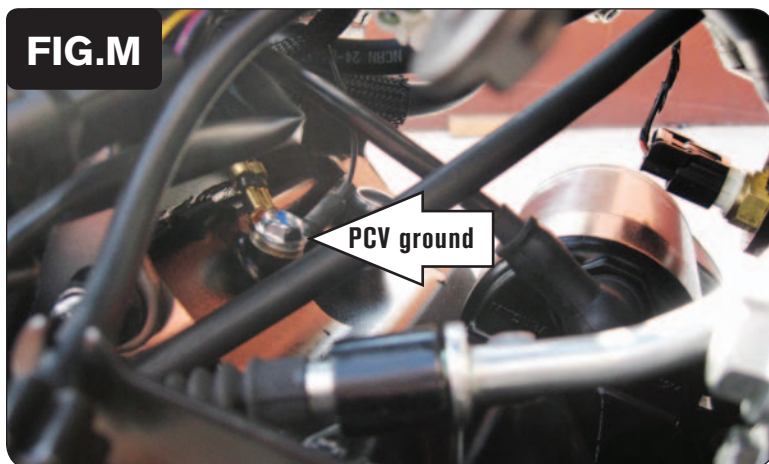

13 Secure the ground eyelet of the PCV wiring harness to the ground bolt on top of the engine case and rear of the starter (Fig. M).

14 Make sure the wiring harness is free of any hot or moving parts, and reinstall the airbox, fuel tank, seat, and body panels.

Optional inputs:

Speed - YELLOW wire of 3-pin BLACK connector from c/s sprocket (YEL-PINK-BLK)

Engine Temperature - ORANGE wire of cylinder temp sensor

12v source for Auto-tune - RED wire of 3-pin connector for tail light - under seat