

[POWER COMMANDER V]

FUEL AND IGNITION

2011-2013 Husqvarna 511 models

Installation Instructions



PARTS LIST

- 1 Power Commander
- 1 USB Cable
- 1 Installation Guide
- 2 Power Commander Decals
- 2 Dynojet Decals
- 2 Velcro strips
- 1 Alcohol swab
- 2 Posi-taps

THE IGNITION MUST BE TURNED OFF BEFORE INSTALLATION!

THE LATEST POWER COMMANDER SOFTWARE AND MAP FILES CAN BE DOWNLOADED FROM OUR WEB SITE AT:
www.powercommander.com

PLEASE READ ALL DIRECTIONS BEFORE STARTING INSTALLATION

Dynojet

2191 Mendenhall Drive North Las Vegas, NV 89081 (800) 992-4993 www.powercommander.com

POWER COMMANDER V INPUT ACCESSORY GUIDE

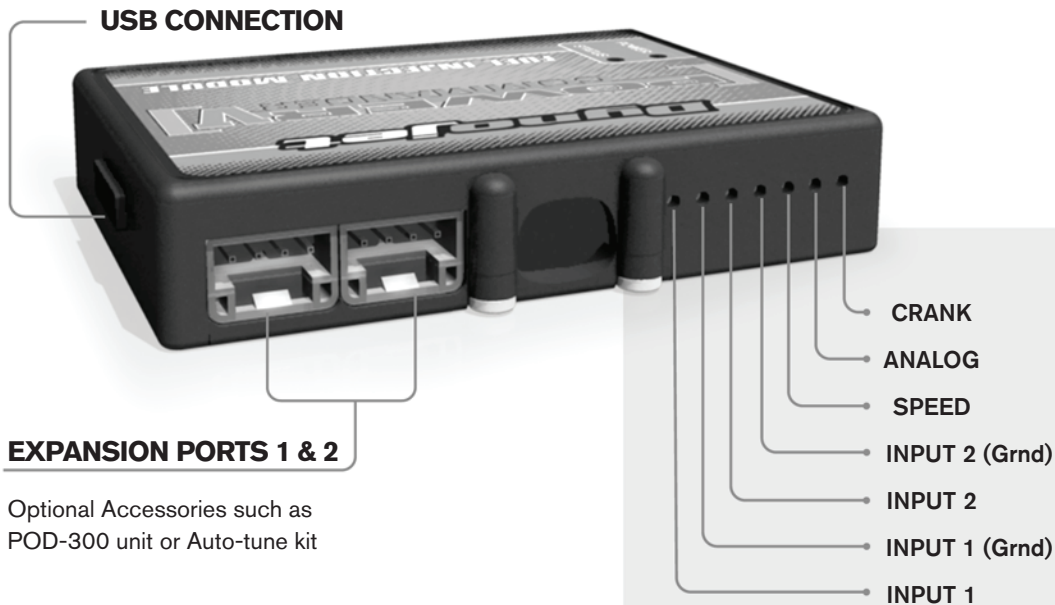

Wire connections:

To input wires into the PCV first remove the rubber plug on the backside of the unit and loosen the screw for the corresponding input. Using a 22-24 gauge wire strip about 10mm from its end. Push the wire into the hole of the PCV until it stops and then tighten the screw. Make sure to reinstall the rubber plug.

NOTE: If you tin the wires with solder it will make inserting them easier.

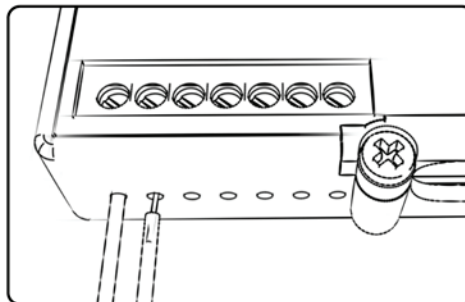

ACCESSORY INPUTS

Map -

(Input 1 or 2) The PCV has the ability to hold 2 different base maps. You can switch on the fly between these two base maps when you hook up a switch to the MAP inputs. You can use any open/close type switch. The polarity of the wires is not important. When using the Autotune kit one position will hold a base map and the other position will let you activate the learning mode. When the switch is "CLOSED" Autotune will be activated. (Set to Switch Input #1 by default.)

Shifter-

(Input 1 or 2) These inputs are for use with the Dynojet quickshifter. Insert the wires from the Dynojet quickshifter into the SHIFTER inputs. The polarity of the wires is not important. (Set to Switch Input #2 by default.)

Speed-

If your application has a speed sensor then you can tap into the signal side of the sensor and run a wire into this input. This will allow you to calculate gear position in the Control Center Software. Once gear position is setup you can alter your map based on gear position and setup gear dependent kill times when using a quickshifter.

Analog-

This input is for a 0-5v signal such as engine temp, boost, etc. Once this input is established you can alter your fuel curve based on this input in the control center software.

Crank-

Do **NOT** connect anything to this port unless instructed to do so by Dynojet. It is used to transfer crank trigger data from one module to another.

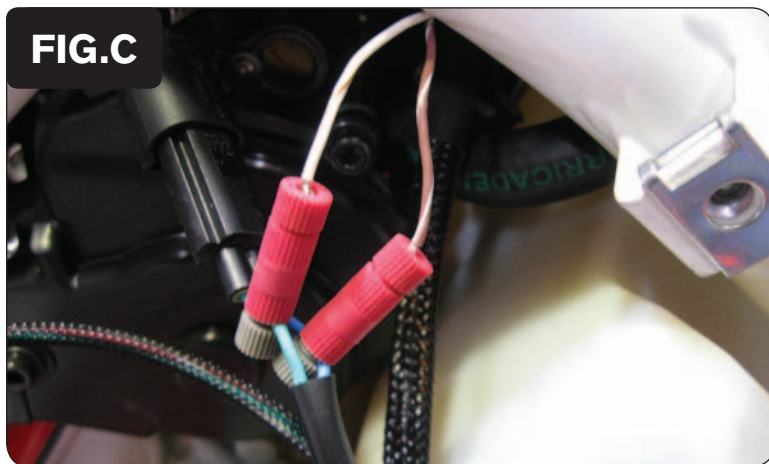
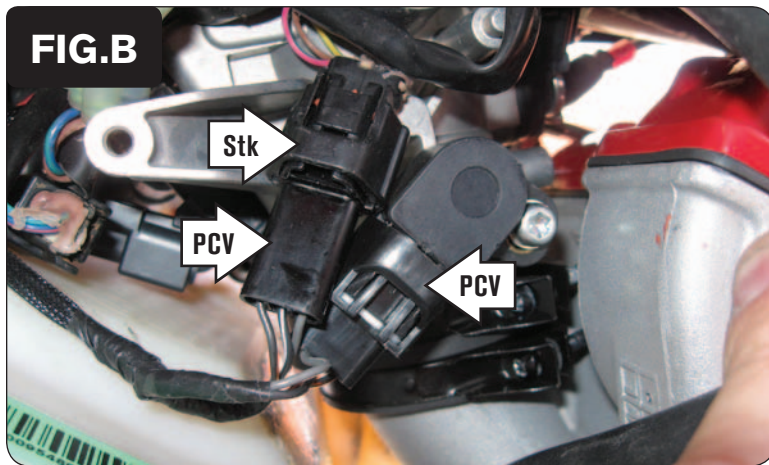
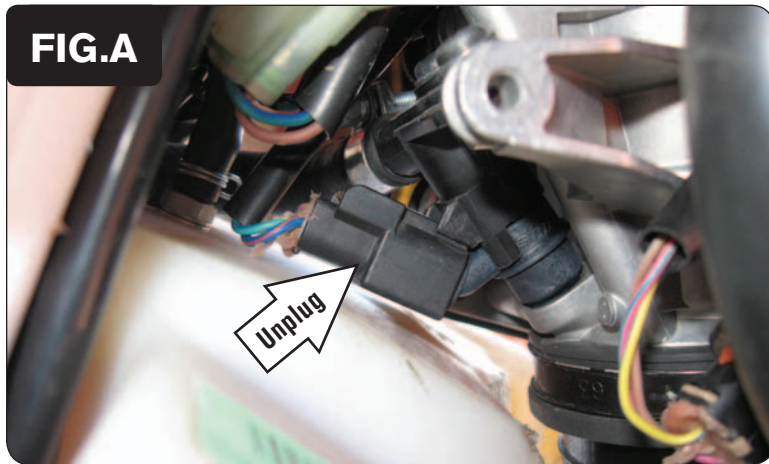

- 1 Remove the seat.
- 2 Route the PCV harness from the left side of the bike and go towards the throttle body.
- 3 Unplug the stock wiring harness from the fuel injector (Fig. A).
- 4 Plug the PCV wiring harness in-line of the fuel injector and the stock wiring harness.
- 5 Locate the Throttle Position Sensor on the right side of the throttle body and unplug the wiring harness from the TPS.
- 6 Plug the PCV wiring harness in-line of the TPS and the stock wiring harness (Fig. B).
- 7 Using the supplied Posi-taps, attach the crank signal input wires of the PCV to the stock Crank Position Sensor wires (Fig. C).

This connection can be found near the bundle of wires towards the rear of the throttle body.

The PCV WHITE/BROWN wire should attach to the stock GREEN wire.

The PCV BROWN/WHITE wire should attach to the stock BLUE wire.

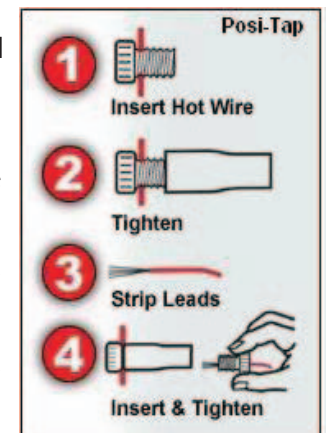

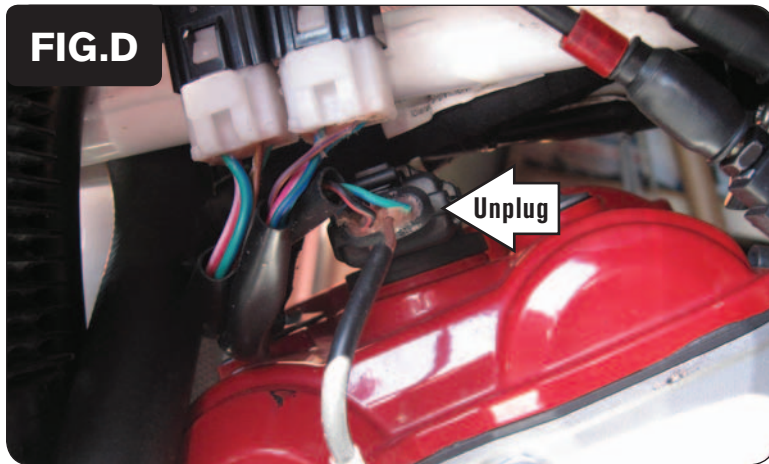

- 8 Unplug the stock wiring harness from the ignition coil (Fig. D).
- 9 Plug the PCV wiring harness in-line of the ignition coil and the stock wiring harness.

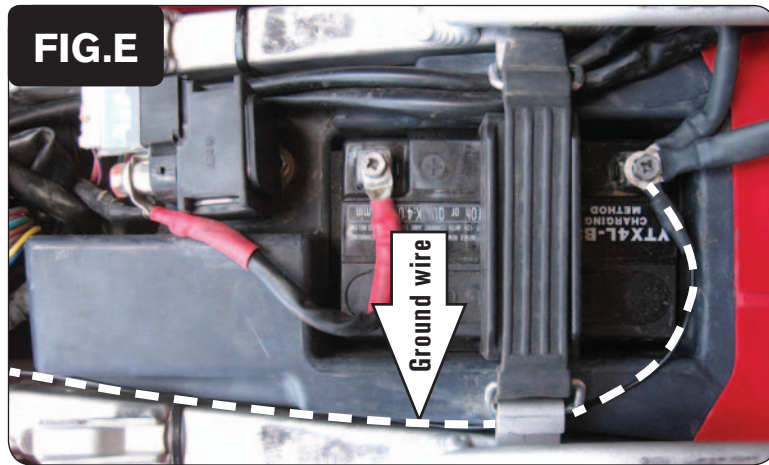

- 10 Attach the PCV ground wire with the small ring lug to the negative (-) terminal of the bike's battery (Fig. E).



- 11 Using the supplied Velcro, attach the PCV module to the inside of the left radiator shroud (Fig. F).
Clean both surfaces with the supplied alcohol swab before attaching the Velcro.
- 12 Reinstall the seat.