

Thank you for purchasing this Dynojet kit. This kit has been developed for a motorcycle which is set to the parameters listed at the right in the "Stage" description. If your motorcycle does not meet any of these parameters please check with Dynojet before installation. For technical assistance contact your Dynojet distributor or call Dynojet U.S.A. (800)-992-4993



**E1120.003**

European Models Only

*1984 Honda V30 Magna*

**Stage 1**

For mildly tuned machines using the stock air-box, with stock or K&N filter. May also be used with a good aftermarket exhaust system  
K&N filter #HA-3010

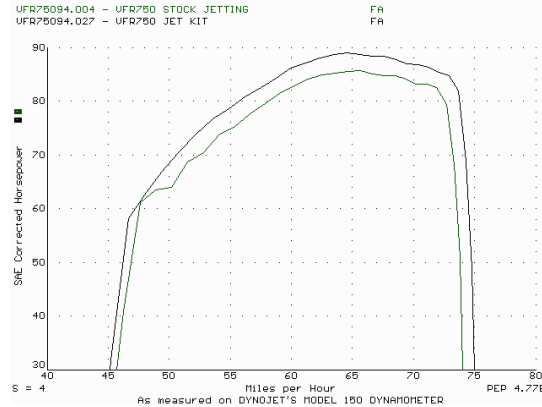

*This graph shows a typical gain with a Dynojet jet kit.*

# WARNING

**NO SMOKING!  
NO OPEN FLAME!  
WHILE INSTALLING  
YOUR DYNJET KIT**

2191 Mendenhall Dr. Suite 105  
North Las Vegas, NV 89031  
TEL: 702-399-1423  
FAX: 702-399-1431  
8am-5pm Pacific Time  
Monday through Friday

Website Address  
<http://www.dynojet.com>

The manufacturer and seller make no warranties express or implied which extend beyond the description of the goods contained herein. Any description of this product is for the purpose of identifying it and shall not be deemed to create an express warranty.

## Parts List

4	Main Jets	DJ100
4	Main Jets	DJ104
1	Slide Drill	DD #7/64
4	Fuel Needles	DNO109
4	Adjusting Washers	DW0001
4	E-Clips	DE0001

## STAGE ONE INSTRUCTIONS

1. Remove the vacuum slide from carbs. Remove stock needles & spacers, noting order of assembly. Using the slide drill (DD #7/64) provided, drill your slide lift holes (Fig. A), the picture may not show your slide exactly. Drill your existing slide lift holes only, do **not** drill any new holes and do **not** drill the needle hole.
2. Install Dynojet needles on groove #3, using all stock spacers (Fig. A). Install the Dynojet washer above the E-clip.
3. Remove the main jets and replace with the Dynojet main jets provided. Use the DJ100 main jets with stock exhaust pipe, or use the DJ104 main jets with aftermarket header or slip-on with high flowing baffles. Be sure that the jets you are changing are the main jets.
4. Locate the Fuel Mixture Screw (Fig. B). Carefully turn mixture screw clockwise until lightly seated, then back out 4 turns.

**DYNOJET**

E1120.003

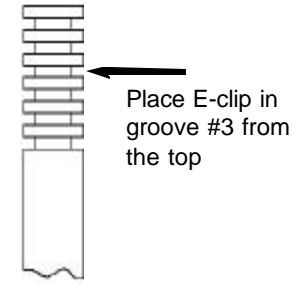

Fig. A

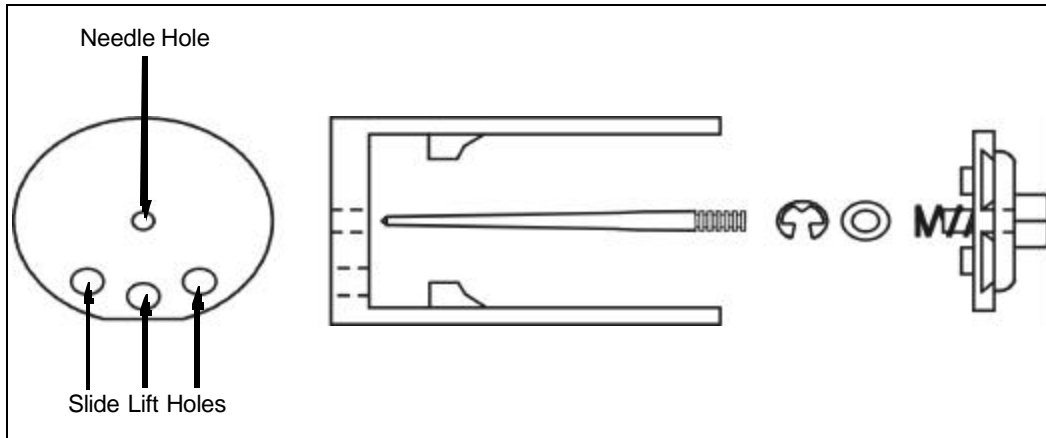

Fig. B

