

Carburetor Re-calibration kit
E2158.001
 European Models only
 1995-98 Kawasaki VN800
 Vulcan & Classic
 Stage 1

For mildly tuned machines using the stock airbox,
 with stock or aftermarket filter. May also be used
 with a good aftermarket exhaust system.
 K&N Filter N/A.

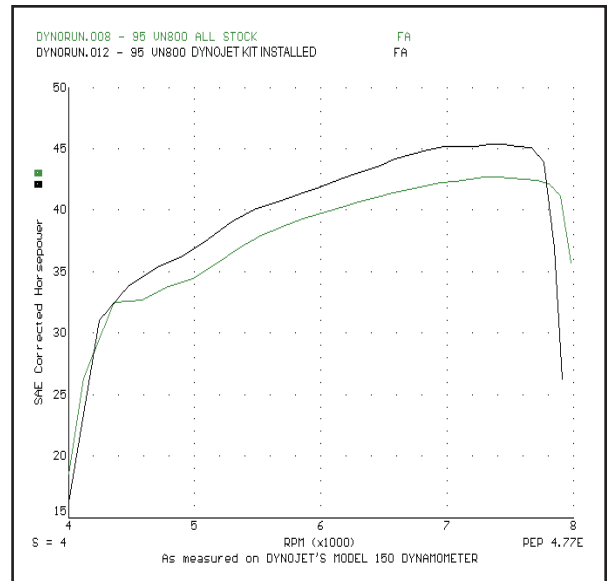

This graph shows a typical gain with a Dynojet jet kit.

PARTS LIST		
1	Main Jets	DJ130
1	Main Jets	DJ134
2	Washers	DW0001
1	Fuel Needles	DNO106
1	E-Clips	DE0001

STAGE ONE INSTRUCTIONS

1. Remove vacuum slide from carb. Remove stock needle & spacers, noting order of assembly.
2. Install Dynojet needle on groove# 2, Install the Dynojet washers above the E-clip.
3. Remove the main jet and replace with the Dynojet main jet provided. Use DJ130 when running the stock exhaust.

Use the DJ134 main jets when running aftermarket exhausts with wide open baffles. Be sure that the jet you are changing is the main jet.

4. Locate the Fuel Mixture Screw location(Fig. B).Carefully turn mixture screw clockwise until seated, then back out 3-1/2 turns.



PLACE E-CLIP IN
GROOVE #2
FROM THE TOP

Fig. A

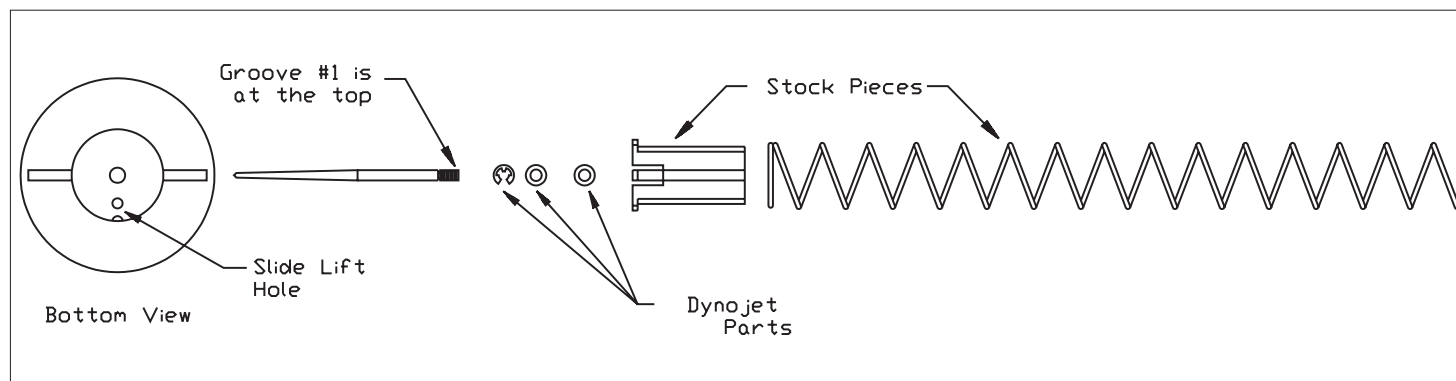

Fig. B

