

Thank you for purchasing this Dynojet kit. This kit has been developed for a motorcycle which is set to the parameters listed at the right in the "Stage" description. If your motorcycle does not meet any of these parameters please check with Dynojet before installation. For technical assistance contact your Dynojet distributor or call Dynojet U.S.A. (800)-992-4993



E2310.003

European Models Only

1981-85 Kawasaki ZX1100

Stage 3

For mildly tuned machines using the stock airbox, with stock or K&N filter. May also be used with a good aftermarket exhaust system.
K&N filter #RC-0984

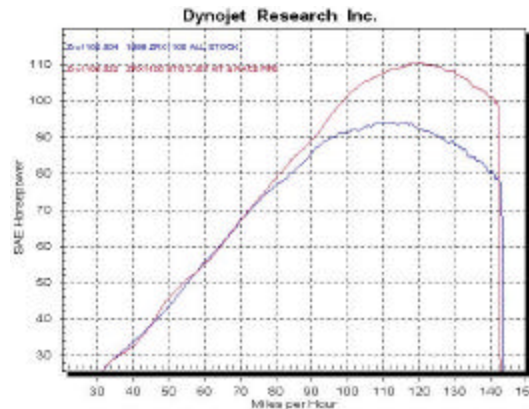

This graph shows a typical gain with a Dynojet jet kit.

WARNING

**NO SMOKING!
NO OPEN FLAME!
WHILE INSTALLING
YOUR DYNOJET KIT**

2191 Mendenhall Dr. Suite 105
North Las Vegas, NV 89031
TEL: 702-399-1423
FAX: 702-399-1431
8am-5pm Pacific Time
Monday through Friday

Website Address
<http://www.dynojet.com>

The manufacturer and seller make no warranties express or implied which extend beyond the description of the goods contained herein. Any description of this product is for the purpose of identifying it and shall not be deemed to create an express warranty.

Parts List

4	Main Jets	DJ155
4	Main Jets	DJ160
4	Fuel Needles	DNO301
4	Adjusting Washers	DW0001
4	E-Clips	DE0001
1	Slide Drill	DD #32

STAGE THREE INSTRUCTIONS

1. Remove the vacuum slide from the carbs. Remove the stock needles & spacers, noting the order of assembly. Locate the slide lift hole using Fig. A. With the slide drill (DD #32) supplied, enlarge your slide lift hole.
2. Install the Dynojet needles on groove #3, using all stock spacers. Install the Dynojet washers above the E-clip.
3. Remove the stock main jets and replace with the Dynojet main jets provided. Use the DJ155 main jet for stock exhaust, and use the DJ160 main jet for aftermarket header or a slip-on with free flowing baffles. Be sure that the jets you are changing are the main jets.
4. Locate the fuel mixture screws (Fig. B). Carefully turn mixture screws clockwise until lightly seated, then turn back out until you find your best idle. Our base setting is 3 turns.

DYNOJET
E2310.003

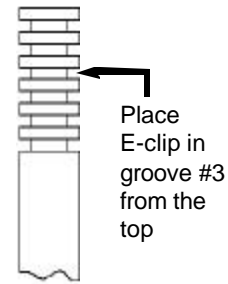

Fig. A

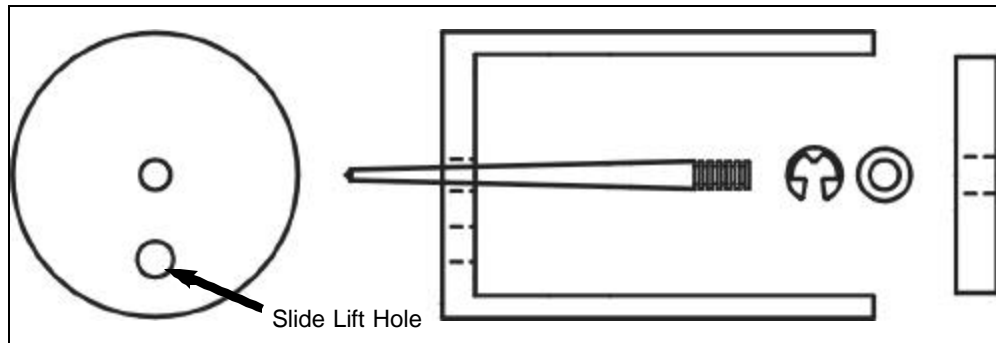

Fig. B

