

Thank you for purchasing this Dynojet kit. This kit has been developed for a motorcycle which is set to the parameters listed at the right in the "Stage" description. If your motorcycle does not meet any of these parameters please check with Dynojet before installation. For technical assistance contact your Dynojet distributor or call Dynojet U.S.A. (800)-992-4993



**E8114.001**

European Models Only

*1996-98 Buell S1 Lightning &  
1997 S3 Thunderbolt*

### **THUNDERSLIDE JET KIT**

For stock or tuned machines using the stock or high flow airbox. May also be used with a good aftermarket exhaust system.

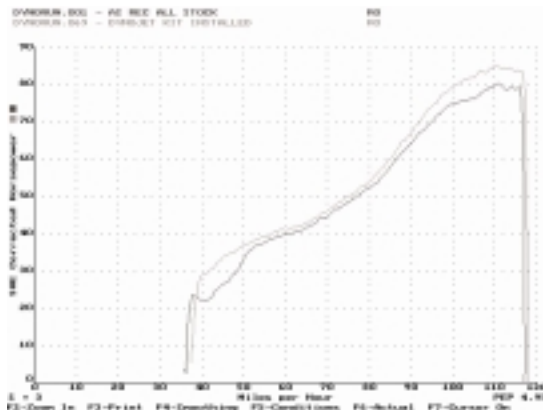

*This graph shows a typical gain with a Dynojet jet kit.*

# **WARNING**

**NO SMOKING!  
NO OPEN FLAME!  
WHILE INSTALLING  
YOUR DYNOJET KIT**

2191 Mendenhall Dr. Suite 105  
North Las Vegas, NV 89031  
TEL: 702-399-1423  
FAX: 702-399-1431  
8am-5pm Pacific Time  
Monday through Friday

**Website Address**

<http://www.dynojet.com>

The manufacturer and seller make no warranties express or implied which extend beyond the description of the goods contained herein. Any description of this product is for the purpose of identifying it and shall not be deemed to create an express warranty.

<b>Parts List</b>		
1	Main Jet	BJ165
1	Main Jet	BJ175
1	Main Jet	BJ185
1	Main Jet	BJ195
1	Thunder Slide	DTS005
1	Diaphragm Retainer Upper	DTS002
1	Diaphragm Retainer Lower	DTS004
1	Fuel Needle	DNO891
1	E-Clip	DE0001
1	Needle Spacer	THNR01
1	Slide Spring	DSP009
1	Emulsion Tube	DET007
1	Slow Jet	DJSJ045
1	Diaphragm Instructions	DI8114S

## Emulsion Tube & Mixture Screw Instructions

**DYNOJET**

**E8114.001**

1. Remove the carburetor float bowl. Remove the stock main jet and remove the emulsion tube (Fig. A), sometimes referred to as the main jet holder. Replace the stock emulsion tube with the Dynojet tube provided. When the Dynojet emulsion tube is fully seated there will still be threads visible.
2. Install the Dynojet main jet provided. Use the BJ175 main jet with a completely stock bike. Use the BJ185 main jet if running the stock air box and high flow aftermarket exhaust. Use the BJ185 main jet if running an aftermarket air box and stock exhaust. When using a complete aftermarket exhaust with a high flow baffle and aftermarket airbox install the BJ195 main jet.
3. Install the slow jet (DJSJ045) provided.
4. Locate the fuel mixture screw (Fig. B). Carefully turn mixture screw clockwise until seated. Turn out 2-1/2 turns when running the stock exhaust and 3 turns when running an aftermarket exhaust.

Fig. A

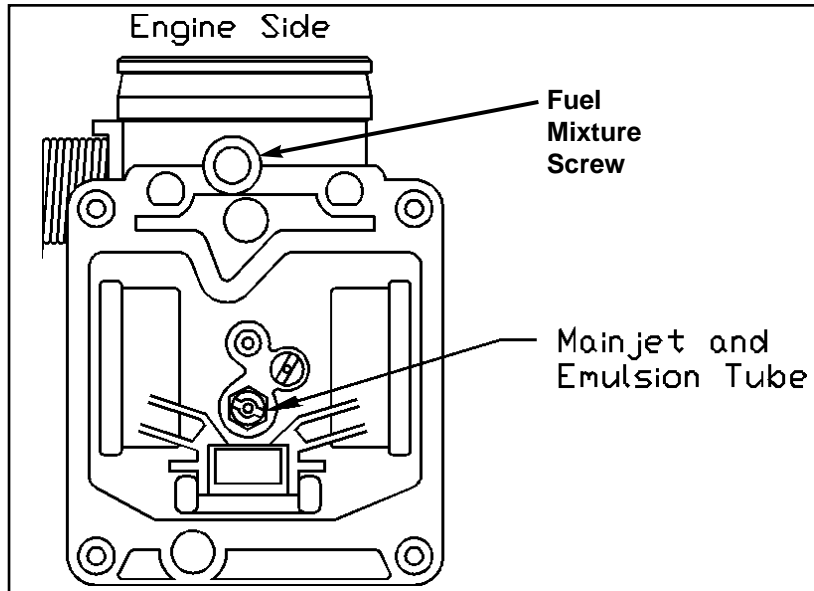

# THUNDERSLIDE DIAPHRAGM - INSTALLATION INSTRUCTIONS

**DYNOJET**  
DI8114S.001

1. Remove the carb top, slide spring & needle retainer.
2. Carefully remove the original rubber diaphragm from the metal slide, (stock rubber diaphragm will be installed on Thunderslide), by gently pulling at the inner edge of the diaphragm in a circular motion until diaphragm is out of the stock slide retaining groove.
3. To assemble the stock diaphragm on the ThunderSlide, first install the larger slide retainer, (DTS004) with radial grooves facing up, on to the slide (Fig. A). You will notice that the slide has a collar on the top, which you will have to push the larger retainer past.
4. Lay the diaphragm on the lower retainer in the same direction it was on the stock slide.
5. Press the small slide retainer (DTS002) with the grooves facing down on top of the diaphragm (Fig. A). You should hear a snap as it goes together. Make sure it is flat and secure on top of the slide and that the diaphragm is centered.
6. Install the e-clip on groove #4 of the Dynojet needle. Install the Thunder slide, Dynojet needle, needle spacer, white needle retainer and Dynojet slide spring (DSP009) into the carb body (Fig. B).

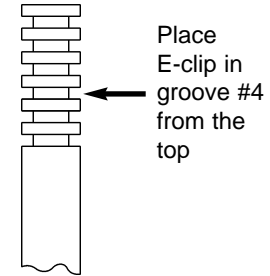

Fig. A

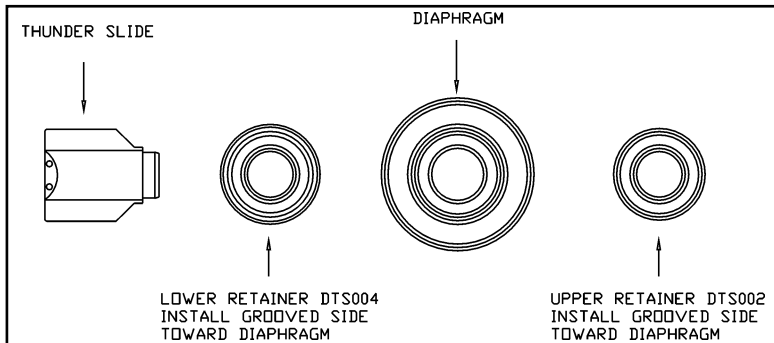

Fig. B

