

[POWER COMMANDER V]

2017-2018 KTM RC390

2017-2018 KTM 390 Duke

Installation Instructions



PARTS LIST

- 1 Power Commander
- 1 USB Cable
- 1 Installation Guide
- 2 Power Commander Decals
- 2 Dynojet Decals
- 2 Velcro strips
- 1 Alcohol swab
- 2 Zip ties

**THE IGNITION MUST BE TURNED
OFF BEFORE INSTALLATION!**

THE LATEST POWER COMMANDER
SOFTWARE AND MAP FILES CAN BE
DOWNLOADED FROM OUR WEB SITE AT:
www.powercommander.com

PLEASE READ ALL DIRECTIONS BEFORE STARTING INSTALLATION

Dynojet

2191 Mendenhall Drive North Las Vegas, NV 89081 (800) 992-4993 www.powercommander.com

POWER COMMANDER V INPUT ACCESSORY GUIDE

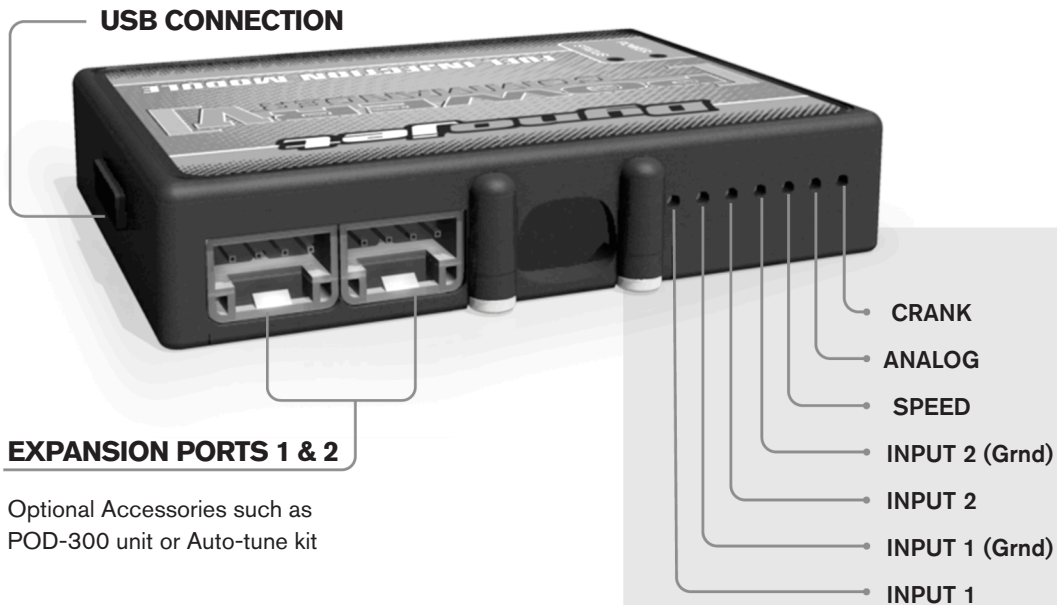

Wire connections:

To input wires into the PCV first remove the rubber plug on the backside of the unit and loosen the screw for the corresponding input. Using a 22-24 gauge wire strip about 10mm from its end. Push the wire into the hole of the PCV until it stops and then tighten the screw. Make sure to reinstall the rubber plug.

NOTE: If you tin the wires with solder it will make inserting them easier.

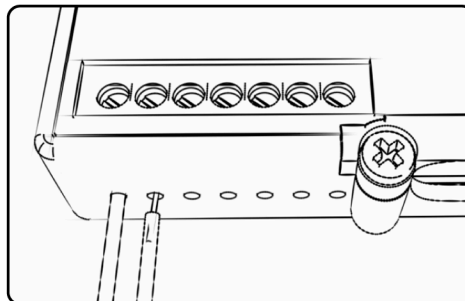

ACCESSORY INPUTS

Map -

(Input 1 or 2) The PCV has the ability to hold 2 different base maps. You can switch on the fly between these two base maps when you hook up a switch to the MAP inputs. You can use any open/close type switch. The polarity of the wires is not important. When using the Autotune kit one position will hold a base map and the other position will let you activate the learning mode. When the switch is "CLOSED" Autotune will be activated. (Set to Switch Input #1 by default.)

Shifter-

(Input 1 or 2) These inputs are for use with the Dynojet quickshifter. Insert the wires from the Dynojet quickshifter into the SHIFTER inputs. The polarity of the wires is not important. (Set to Switch Input #2 by default.)

Speed-

If your application has a speed sensor then you can tap into the signal side of the sensor and run a wire into this input. This will allow you to calculate gear position in the Control Center Software. Once gear position is setup you can alter your map based on gear position and setup gear dependent kill times when using a quickshifter.

Analog-

This input is for a 0-5v signal such as engine temp, boost, etc. Once this input is established you can alter your fuel curve based on this input in the control center software.

Crank-

Do **NOT** connect anything to this port unless instructed to do so by Dynojet. It is used to transfer crank trigger data from one module to another.



1 Remove the battery access cover, fuel tank cover, and side panels (Fig. A).

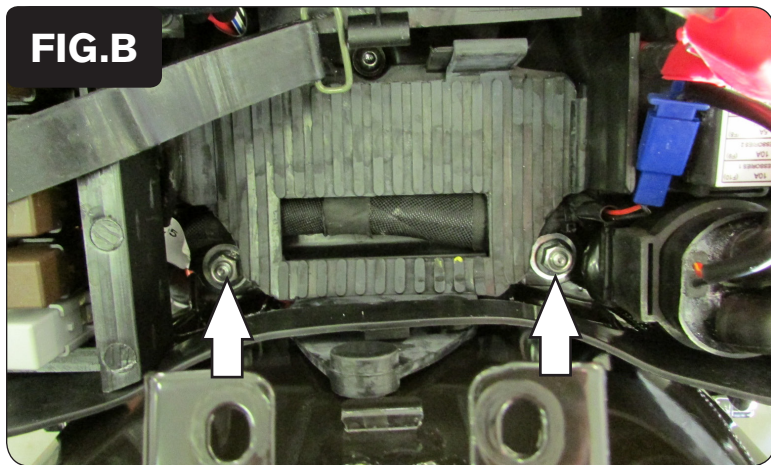

4 Remove the battery.

5 To remove the fuel tank remove the two bolts at the bottom of the battery box (Fig. B).

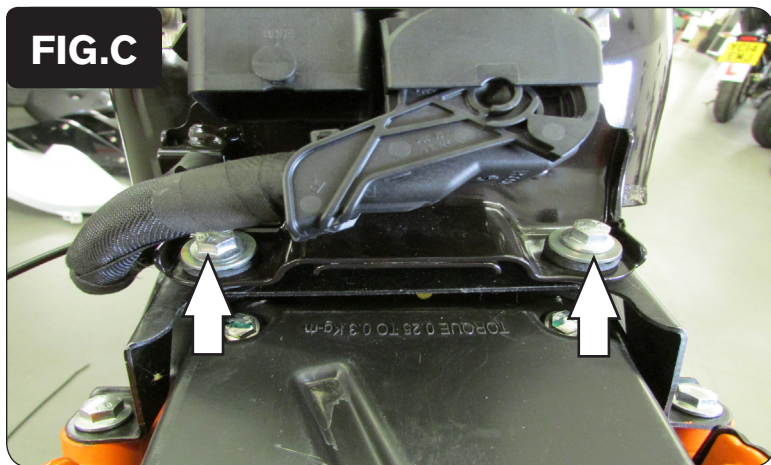

6 Remove the 2 bolts at the rear of the fuel tank (Fig. C).

7 Unplug the wiring harness from the ECU and remove the fuel tank.

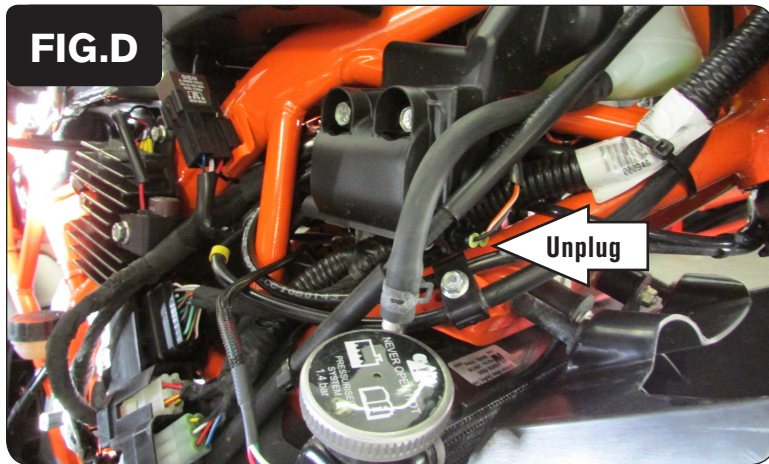

- 8 Unplug the stock wiring harness from the ignition coil (Fig. D).
This is a BLACK, 2 pin connector on the right hand side.

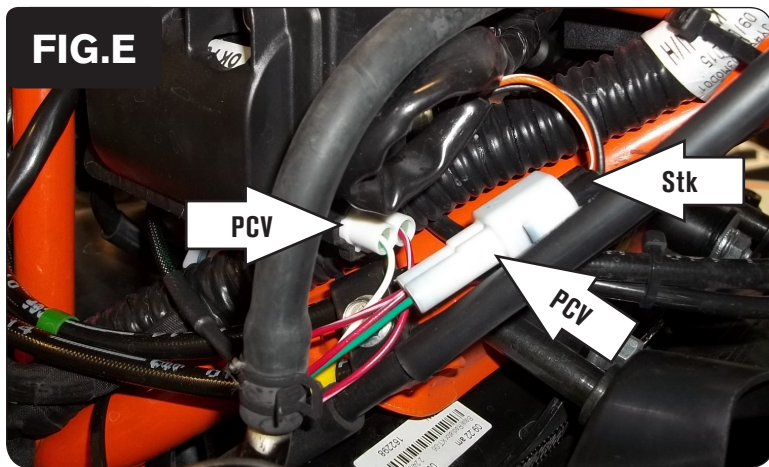

- 9 Plug the PCV in-line of the stock wiring harness and stock ignition coil (Fig. E)



- 10 Unplug the stock Throttle Position Sensor connector (Fig. F).
This is a BLACK, 6 pin connector on the RH side of the throttle body.
- 11 Plug the PCV in-line of the stock TPS and wiring harness.



12 Unplug the wiring harness from the fuel injector (Fig. G).

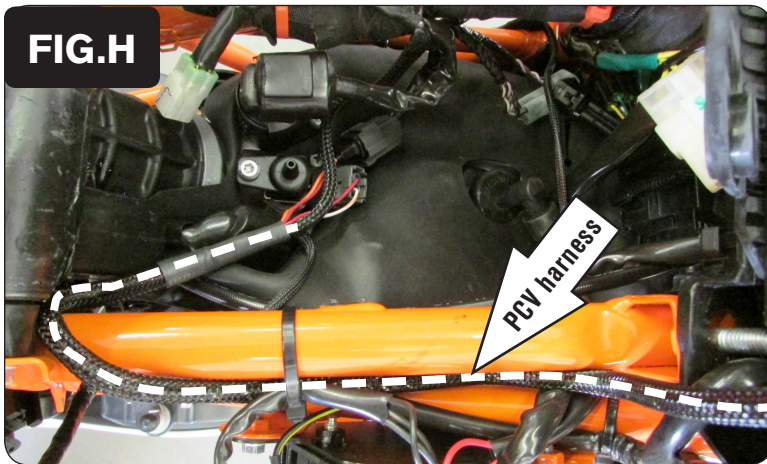

13 Plug the PCV in-line of the stock fuel injector and wiring harness (Fig. H).

14 Route the PCV harness as shown in Figure H and secure to the frame using the zip tie.

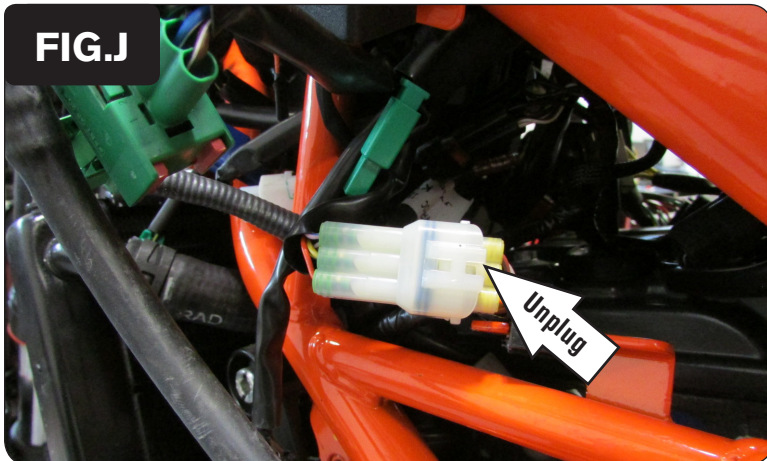

15 Unplug the stock crank position sensor connector (Fig. J).
This is a WHITE, 6 pin connector near the FRT, LH side of the cylinder head.

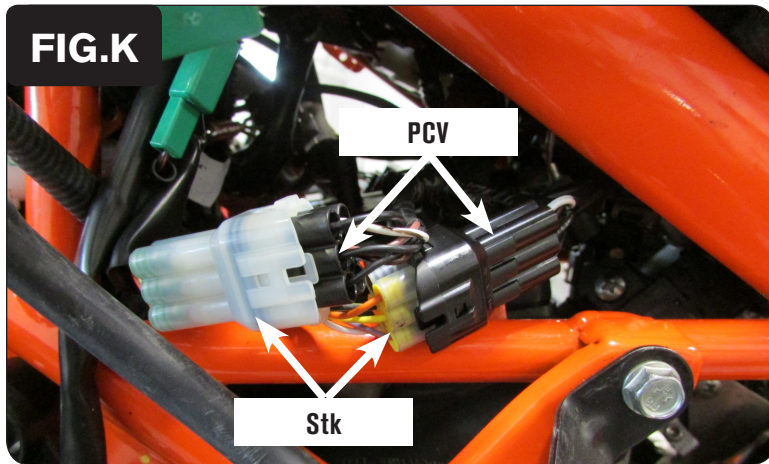

16 Plug the PCV in-line of the stock CPS and wiring harness (Fig. K).

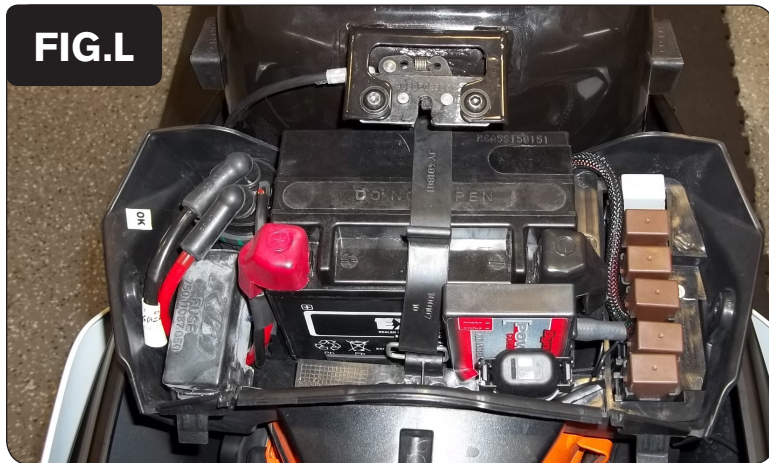

17 Reinstall fuel tank and battery.

18 Secure the PCV to the front of the battery (Fig. L).

19 Attach the ground wire of the PCV to the negative side of the battery.

20 Reinstall bodywork.