

# [POWER COMMANDER V]

**2006-2012 Yamaha FJR1300**

**Installation Instructions**



## **PARTS LIST**

- 1 Power Commander
- 1 USB Cable
- 1 Installation Guide
- 2 Power Commander Decals
- 2 Dynojet Decals
- 2 Velcro strips
- 1 Alcohol swab

**THE IGNITION MUST BE TURNED  
OFF BEFORE INSTALLATION!**

THE LATEST POWER COMMANDER  
SOFTWARE AND MAP FILES CAN BE  
DOWNLOADED FROM OUR WEB SITE AT:  
[www.powercommander.com](http://www.powercommander.com)

**PLEASE READ ALL DIRECTIONS BEFORE STARTING INSTALLATION**

**Dynojet**

2191 Mendenhall Drive North Las Vegas, NV 89081 (800) 992-4993 [www.powercommander.com](http://www.powercommander.com)

# POWER COMMANDER V INPUT ACCESSORY GUIDE

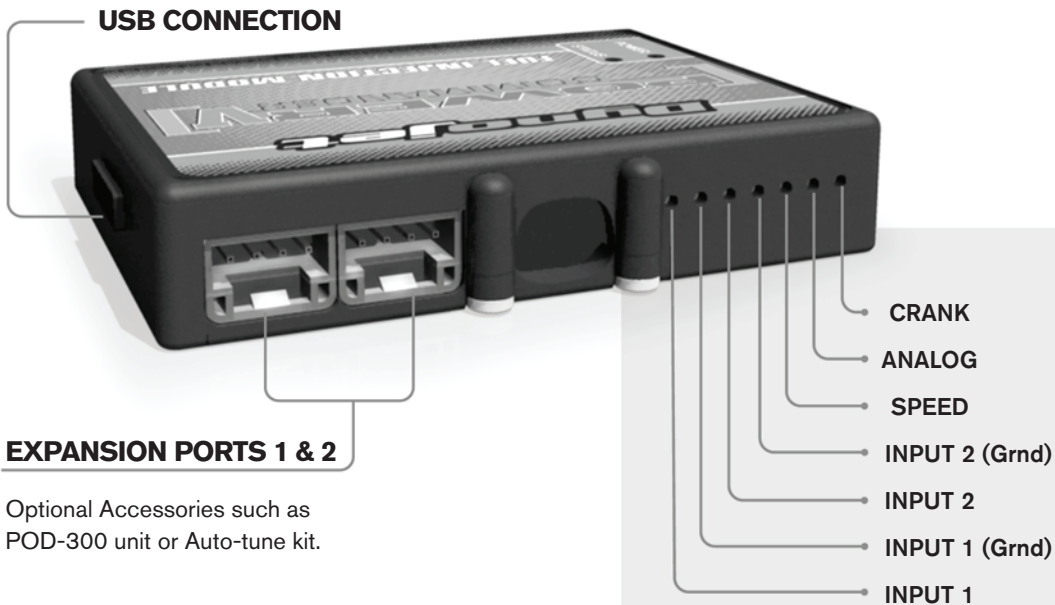

## EXPANSION PORTS 1 & 2

Optional Accessories such as POD-300 unit or Auto-tune kit.

## Wire connections:

To input wires into the PCV first remove the rubber plug on the backside of the unit and loosen the screw for the corresponding input. Using a 22-24 gauge wire strip about 10mm from its end. Push the wire into the hole of the PCV until it stops and then tighten the screw. Make sure to reinstall the rubber plug.

NOTE: If you tin the wires with solder it will make inserting them easier.

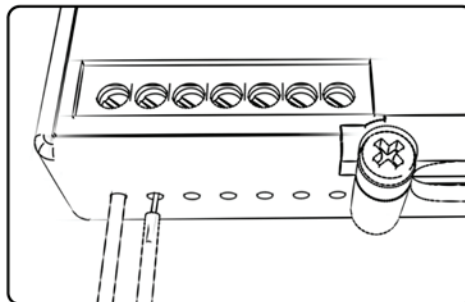

## ACCESSORY INPUTS

### Map -

(Input 1 or 2) The PCV has the ability to hold 2 different base maps. You can switch on the fly between these two base maps when you hook up a switch to the MAP inputs. You can use any open/close type switch. The polarity of the wires is not important. When using the Autotune kit one position will hold a base map and the other position will let you activate the learning mode. When the switch is "CLOSED" Autotune will be activated. (Set to Switch Input #1 by default.)

### Shifter-

(Input 1 or 2) These inputs are for use with the Dynojet quickshifter. Insert the wires from the Dynojet quickshifter into the SHIFTER inputs. The polarity of the wires is not important. (Set to Switch Input #2 by default.)

### Speed-

If your application has a speed sensor then you can tap into the signal side of the sensor and run a wire into this input. This will allow you to calculate gear position in the Control Center Software. Once gear position is setup you can alter your map based on gear position and setup gear dependent kill times when using a quickshifter.

### Analog-

This input is for a 0-5v signal such as engine temp, boost, etc. Once this input is established you can alter your fuel curve based on this input in the control center software.

### Crank-

Do **NOT** connect anything to this port unless instructed to do so by Dynojet. It is used to transfer crank trigger data from one module to another.

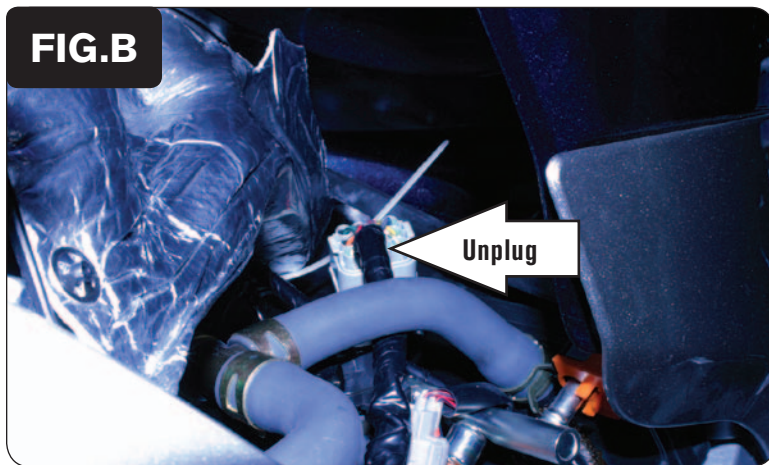
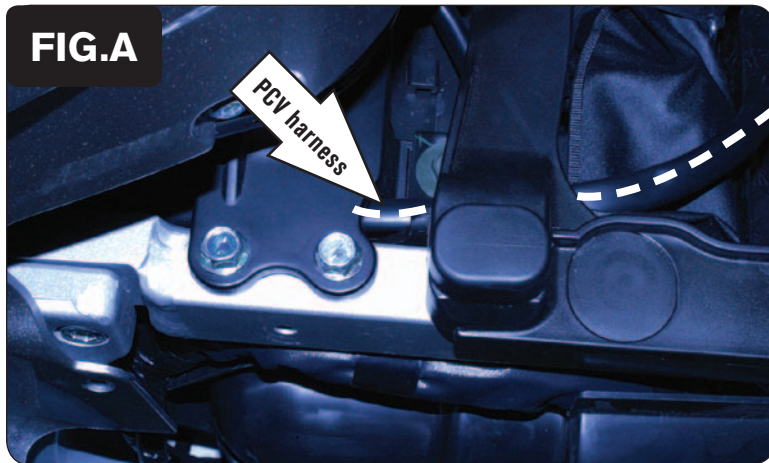

- 1 Remove the main seat.
- 2 Lift the front of the fuel tank up.
- 3 Place the PCV in the vicinity of the tool kit temporarily.
- 4 Route the wiring harness from the PCV towards the front of the air box on the left hand side of the bike. Route the harness between the fuel tank and the frame (Fig. A).

*The bracket for the fuel tank will need to be loosened to fit the connectors through.*

- 5 Pull the heatshield back that is on top of the air box to expose the wiring harness.
- 6 Unplug the stock connector from the throttle bodies to the main wiring harness (Fig. B).

- 7 Plug the connectors from the PCV in-line of the stock wiring harness and throttle bodies (Fig. C).



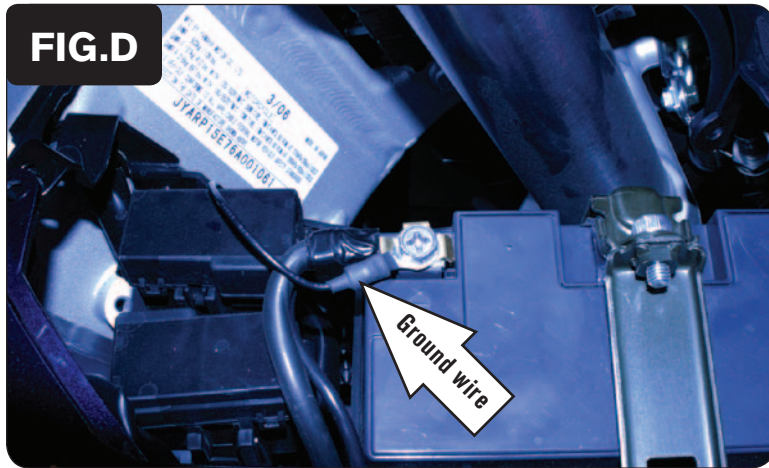

- 8 Route the ground wire to the right hand side of the throttle bodies. Route the ground wire under the frame cross member and above the radiator.
- 9 Attach the ground wire of the PCV to the negative side of the battery (Fig. D).

- 10 Install the PCV in the tool kit tray (Fig. E) using the supplied velcro.  
Make sure to clean both surfaces with the supplied alcohol swab before attaching velcro.
- 11 Make sure all wires are routed so that they will not get pinched.
- 12 Reinstall the fuel tank and seats.

Note: It is recommended to disconnect the stock O2 sensor to get the full potential out of the bike and the Power Commander. Follow the wires coming out of your exhaust and disconnect these wires where it goes into the main wiring harness.

#### Optional inputs:

**Temperature input** - GREEN/WHITE wire - pin #31 of ECU.

**12v source for Auto-tune** - BLUE wire of tail light connector which is behind the left hand side panel.