

[POWER COMMANDER V]

**2005-2008 Suzuki Boulevard
C50, C50 SE, & M50**

Installation Instructions



PARTS LIST

- 1 Power Commander
- 1 USB Cable
- 1 Installation Guide
- 2 Power Commander Decals
- 2 Dynojet Decals
- 2 Velcro strips
- 1 Alcohol swab

**THE IGNITION MUST BE TURNED
OFF BEFORE INSTALLATION!**

THE LATEST POWER COMMANDER
SOFTWARE AND MAP FILES CAN BE
DOWNLOADED FROM OUR WEB SITE AT:
www.powercommander.com

PLEASE READ ALL DIRECTIONS BEFORE STARTING INSTALLATION

Dynojet

2191 Mendenhall Drive North Las Vegas, NV 89081 (800) 992-4993 www.powercommander.com

POWER COMMANDER V INPUT ACCESSORY GUIDE

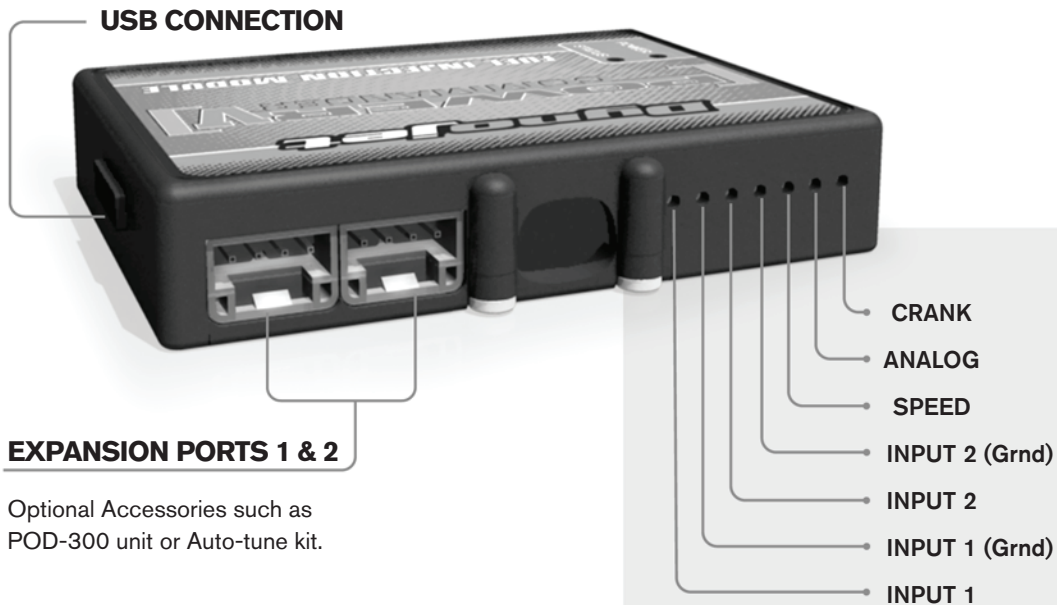

Wire connections:

To input wires into the PCV first remove the rubber plug on the backside of the unit and loosen the screw for the corresponding input. Using a 22-24 gauge wire strip about 10mm from its end. Push the wire into the hole of the PCV until it stops and then tighten the screw. Make sure to reinstall the rubber plug.

NOTE: If you tin the wires with solder it will make inserting them easier.

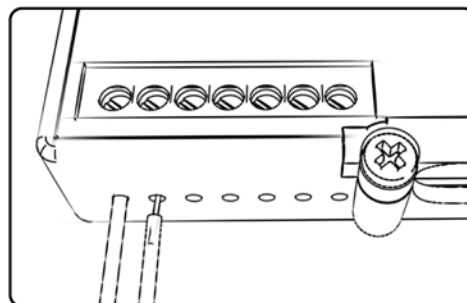

ACCESSORY INPUTS

Map -

(Input 1 or 2) The PCV has the ability to hold 2 different base maps. You can switch on the fly between these two base maps when you hook up a switch to the MAP inputs. You can use any open/close type switch. The polarity of the wires is not important. When using the Autotune kit one position will hold a base map and the other position will let you activate the learning mode. When the switch is "CLOSED" Autotune will be activated. (Set to Switch Input #1 by default.)

Shifter-

(Input 1 or 2) These inputs are for use with the Dynojet quickshifter. Insert the wires from the Dynojet quickshifter into the SHIFTER inputs. The polarity of the wires is not important. (Set to Switch Input #2 by default.)

Speed-

If your application has a speed sensor then you can tap into the signal side of the sensor and run a wire into this input. This will allow you to calculate gear position in the Control Center Software. Once gear position is setup you can alter your map based on gear position and setup gear dependent kill times when using a quickshifter.

Analog-

This input is for a 0-5v signal such as engine temp, boost, etc. Once this input is established you can alter your fuel curve based on this input in the control center software.

Crank-

Do **NOT** connect anything to this port unless instructed to do so by Dynojet. It is used to transfer crank trigger data from one module to another.

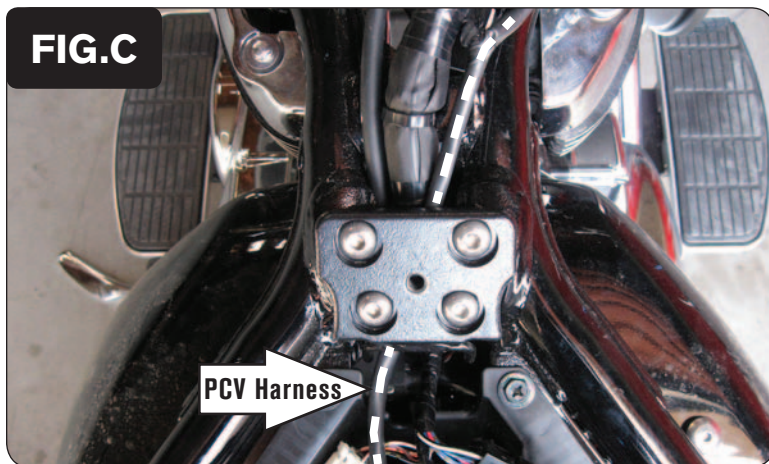
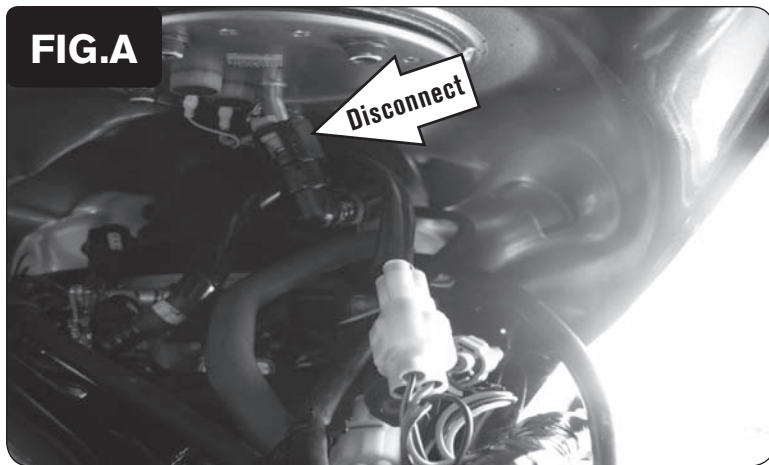

- 1 Remove the main seat and the passenger seat.
- 2 Remove the center gauge cluster
- 3 Remove the fuel tank. To remove the tank unplug the fuel pump connector and disconnect the fuel line (Fig. A).

- 4 Install the PCV to the battery tray.
Use the supplied alcohol swab to clean both surfaces and then attach the unit using the supplied Velcro.
- 5 Attach the ground wire of the PCV to the negative side of the battery (Fig. B).

- 6 Route the PCV harness underneath the frame crossover (Fig. C).
It may be necessary to unbolt the bracket to fit the PCV connectors underneath.

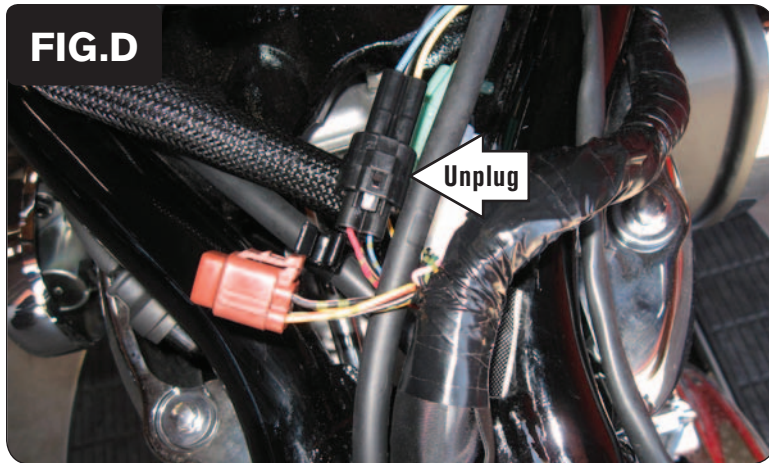

- 7 Locate the Throttle Position Sensor connector (Fig. D).

This is a 3-pin BLACK connector located on the right hand side of the frame next to the main wiring harness and fuel pump connector.

Unplug the TPS connector.



- 8 Plug the WHITE connectors from the PCV in-line of the TPS connector and main wiring harness (Fig. E).

There are two other sets of connectors that these can be plugged into, make sure you go to the BLACK connectors.

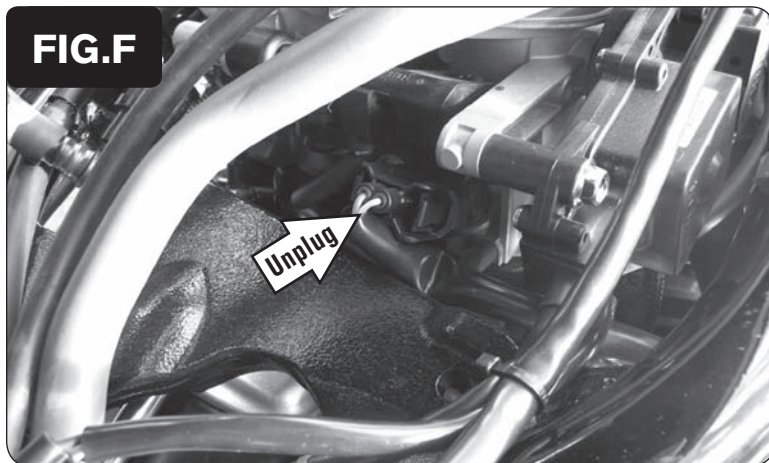

- 9 Unplug the stock wiring harness from the rear fuel injector (Fig. F).

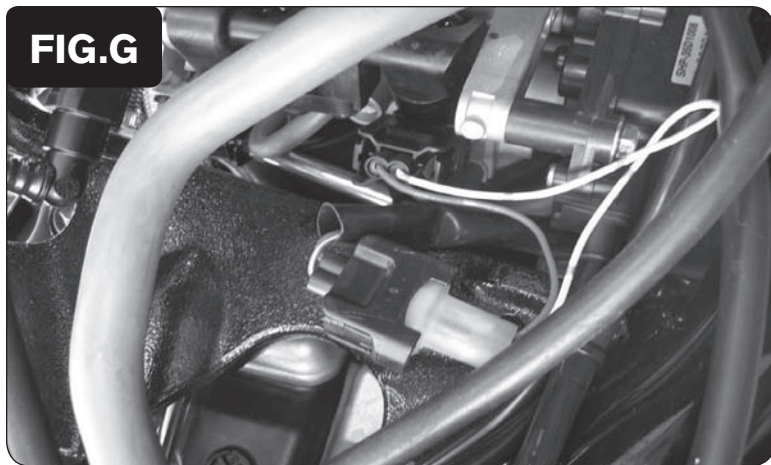

- 10 Plug the YELLOW colored wires from the PCV in-line of the rear fuel injector and the stock wiring harness (Fig. G).



- 11 Loosen the clamp that holds the intake duct to the throttle body. Lift up on the intake duct so the PCV harness can be routed underneath this duct and in front of the throttle body (Fig. H).

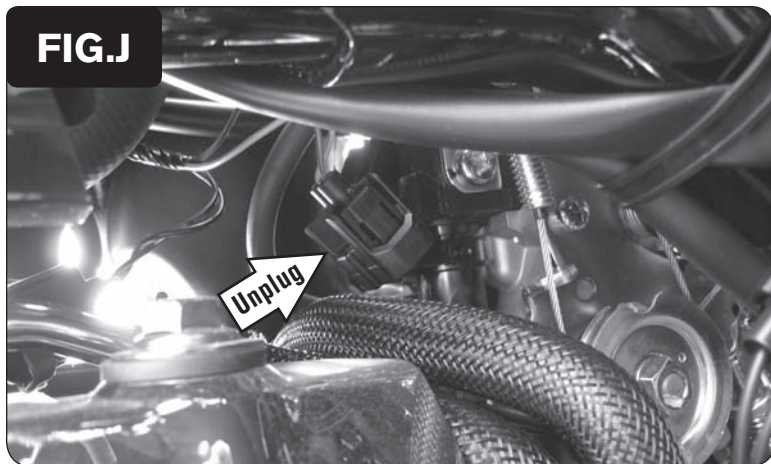

- 12 Unplug the stock wiring harness from the front fuel injector (Fig. J).

FIG. K

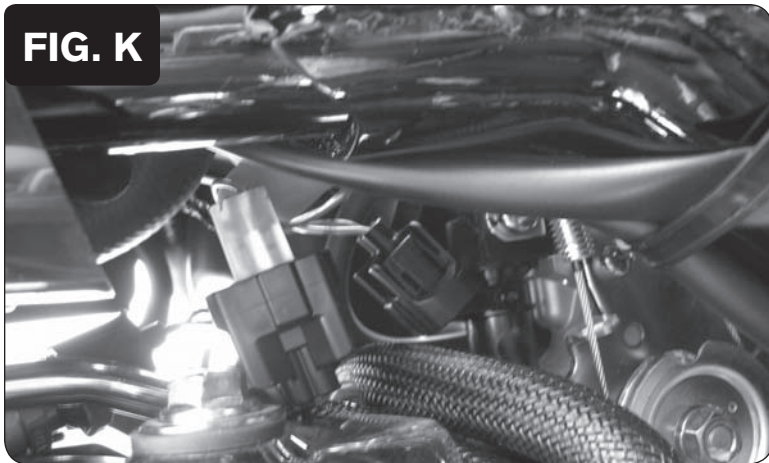

- 13 Plug the ORANGE colored wires from the PCV in-line of the front fuel injector and stock wiring harness (Fig. K).
- 14 Reinstall the intake duct and tighten the clamp
- 15 Reinstall the fuel tank and seats.