

[POWER COMMANDER V]

FUEL AND IGNITION

2015-2018 Yamaha XSR700

Installation Instructions



PARTS LIST

- 1 Power Commander
- 1 USB Cable
- 1 Installation Guide
- 2 Power Commander Decals
- 2 Dynojet Decals
- 3 Velcro strips
- 1 Alcohol swab

**THE IGNITION MUST BE TURNED
OFF BEFORE INSTALLATION!**

THE LATEST POWER COMMANDER
SOFTWARE AND MAP FILES CAN BE
DOWNLOADED FROM OUR WEB SITE AT:
www.powercommander.com

PLEASE READ ALL DIRECTIONS BEFORE STARTING INSTALLATION

Dynojet

2191 Mendenhall Drive North Las Vegas, NV 89081 (800) 992-4993 www.powercommander.com

POWER COMMANDER V INPUT ACCESSORY GUIDE

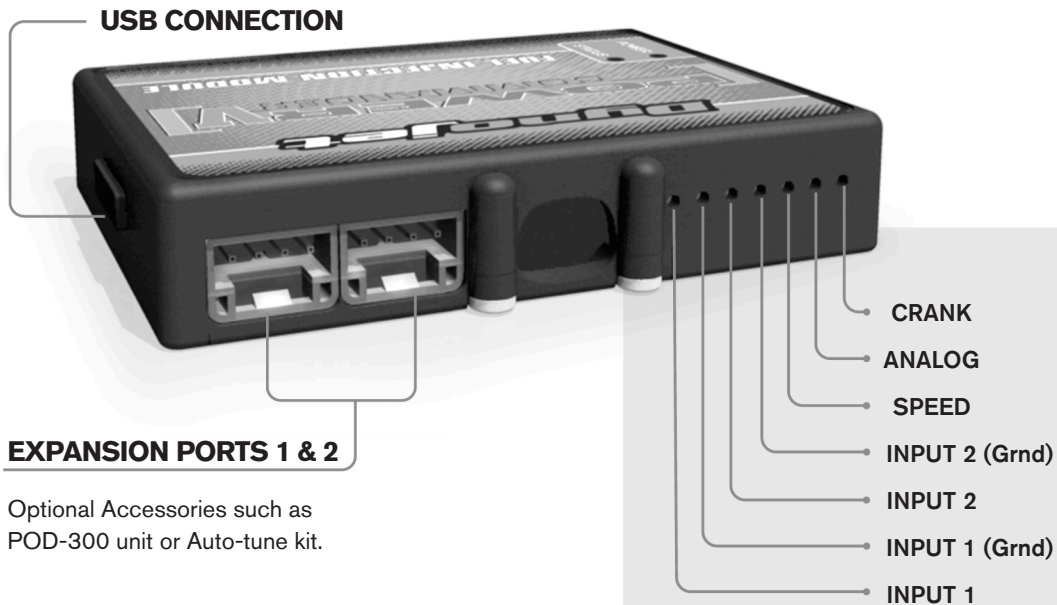

Wire connections:

To input wires into the PCV first remove the rubber plug on the backside of the unit and loosen the screw for the corresponding input. Using a 22-24 gauge wire strip about 10mm from its end. Push the wire into the hole of the PCV until it stops and then tighten the screw. Make sure to reinstall the rubber plug.

NOTE: If you tin the wires with solder it will make inserting them easier.

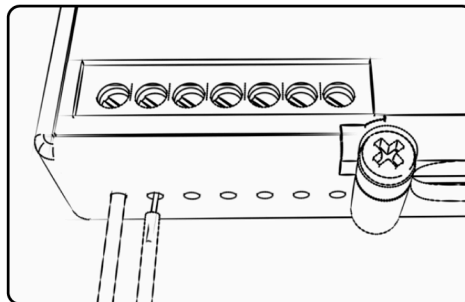

ACCESSORY INPUTS

Map -

(Input 1 or 2) The PCV has the ability to hold 2 different base maps. You can switch on the fly between these two base maps when you hook up a switch to the MAP inputs. You can use any open/close type switch. The polarity of the wires is not important. When using the Autotune kit one position will hold a base map and the other position will let you activate the learning mode. When the switch is "CLOSED" Autotune will be activated. (Set to Switch Input #1 by default.)

Shifter-

(Input 1 or 2) These inputs are for use with the Dynojet quickshifter. Insert the wires from the Dynojet quickshifter into the SHIFTER inputs. The polarity of the wires is not important. (Set to Switch Input #2 by default.)

Speed-

If your application has a speed sensor then you can tap into the signal side of the sensor and run a wire into this input. This will allow you to calculate gear position in the Control Center Software. Once gear position is setup you can alter your map based on gear position and setup gear dependent kill times when using a quickshifter.

Analog-

This input is for a 0-5v signal such as engine temp, boost, etc. Once this input is established you can alter your fuel curve based on this input in the control center software.

Crank-

Do **NOT** connect anything to this port unless instructed to do so by Dynojet. It is used to transfer crank trigger data from one module to another.

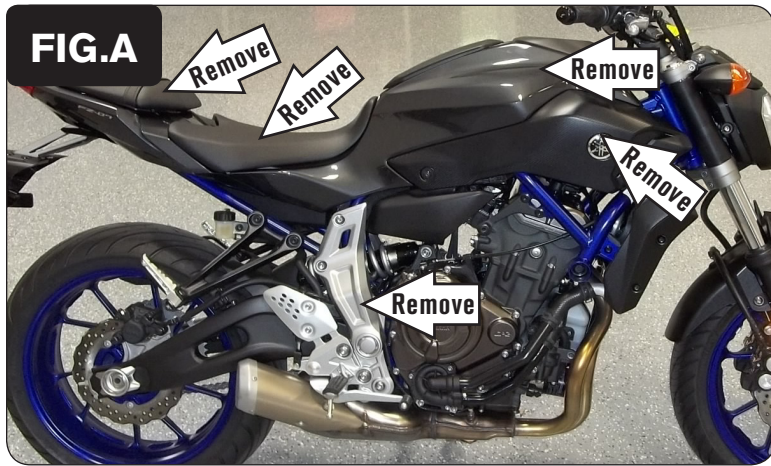

- 1 Remove both seats, both side panels, the bodywork surrounding the fuel tank, the panel between the seats, and the plastic panel above the right footpeg (Fig. A).
- 2 Remove the fuel tank.

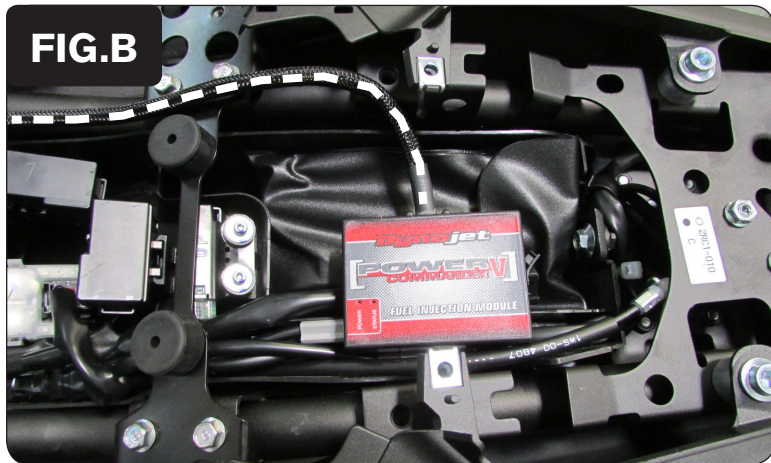

- 3 Store the PCV module in the tail section beneath the passenger seat (tool kit area). The supplied Velcro strips can be used to secure the module.
Clean both surfaces with the supplied alcohol swab prior to applying the Velcro adhesive.
- 4 Route the PCV wiring harness forward along the right side frame rail (Fig. B).

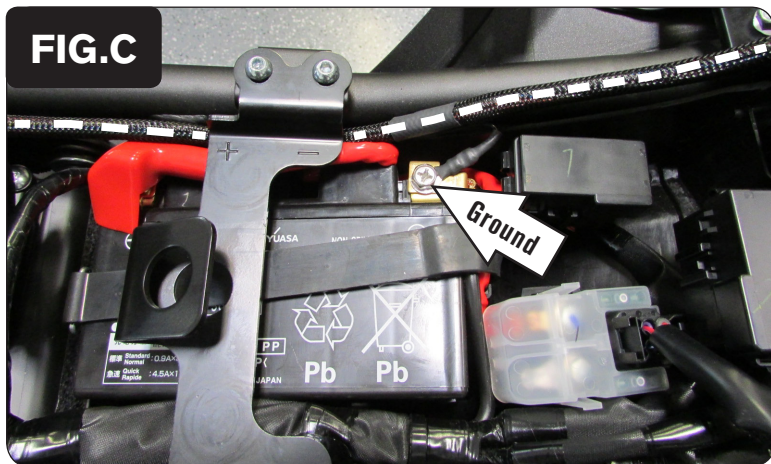

- 5 Secure the PCV ground wire with the small ring lug to the negative (-) terminal of the bike's battery (Fig. C).
- 6 Continue routing the wiring harness forward and towards the throttle bodies.

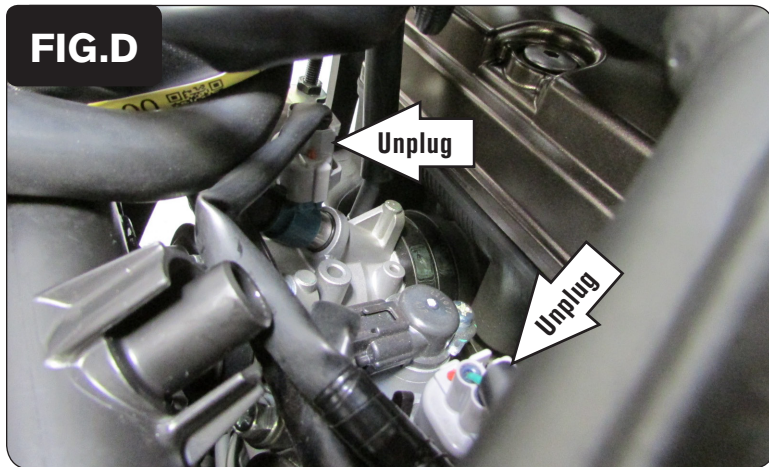

- 7 Unplug the stock wiring harness from both Fuel Injectors (Fig. D).



- 8 Plug the PCV wiring harness in-line of the Fuel Injectors and the stock wiring harness (Fig. E).

The pair of PCV leads with ORANGE colored wires go to the left cylinder injector (#1); and the pair with YELLOW colored wires go to right cylinder (#2).

Only the right cylinder injector connections can be seen in Figure E.

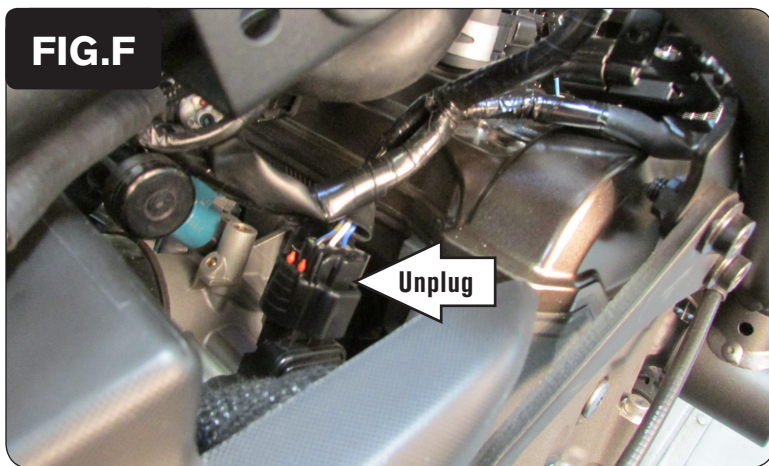

- 9 Unplug the stock wiring harness from the Throttle Position Sensor located on the right side of the throttle bodies (Fig. F).

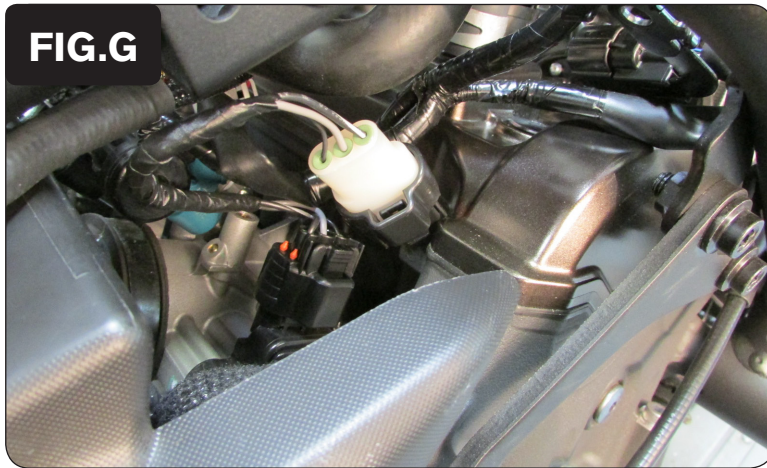

- 10 Plug the PCV wiring harness in-line of the TPS and the stock wiring harness (Fig. G).
- 11 Route the rest of the PCV wiring harness forward towards the top of the engine where the Ignition Coils are located.

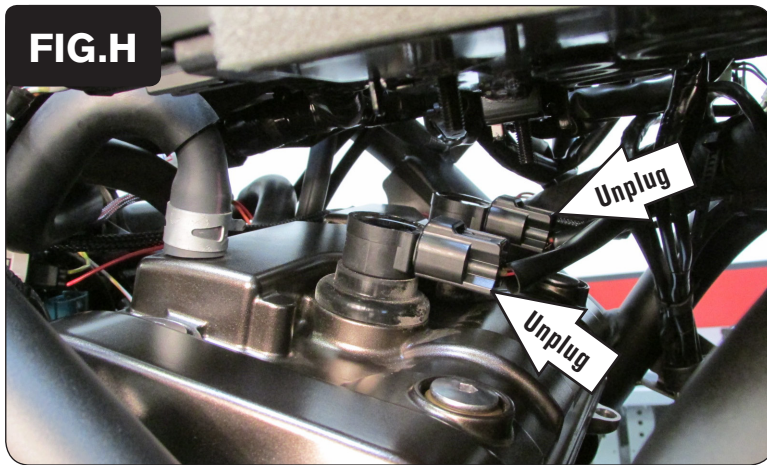

- 12 Unplug the stock wiring harness from both of the Ignition Coils (Fig. H).

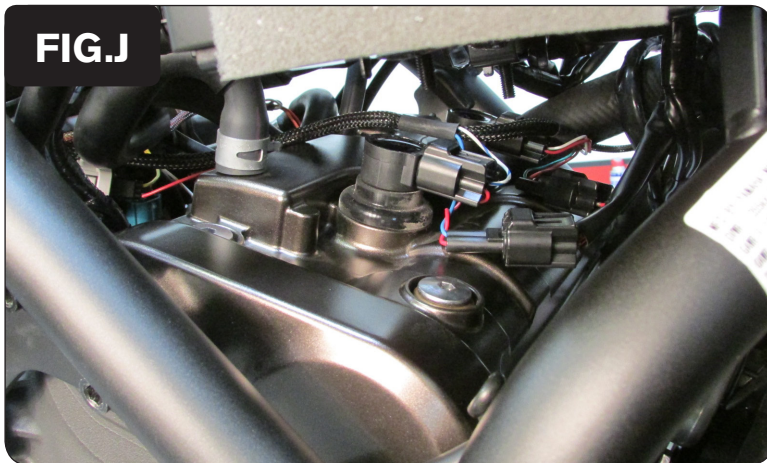

- 13 Plug the PCV wiring harness in-line of the Ignition Coils and the stock wiring harness (Fig. J).
The pair of PCV leads with GREEN colored wires go to the left cylinder coil stick (#1); and the pair with BLUE colored wires go to right cylinder coil stick (#2).
- 14 Route the last pair of connections on the PCV wiring harness out to the left side of the bike below the voltage regulator/rectifier.

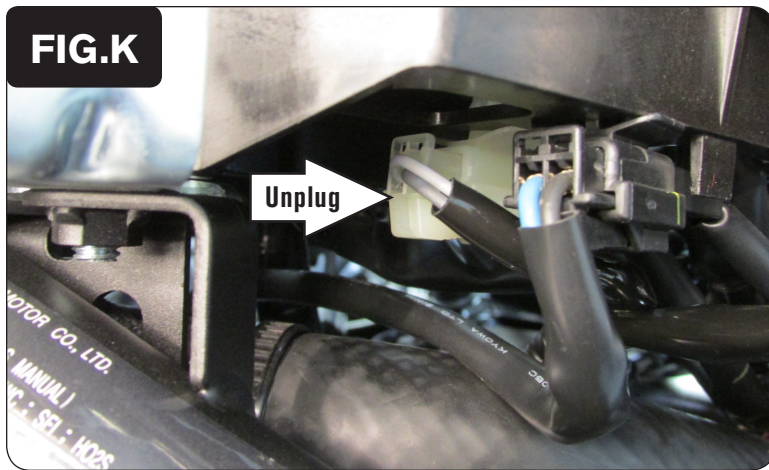

- 15 Just below the regulator/rectifier, locate and unplug the stock connectors for the bike's Crank Position Sensor (Fig. K).

This is a pair of CLEAR (opaque) 2-pin connectors with a WHITE and a GREY wire.

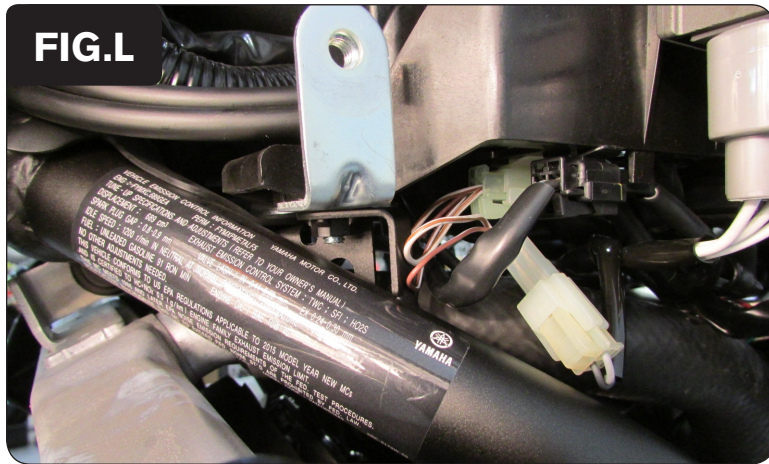

- 16 Plug the PCV wiring harness in-line of the stock CPS connectors (Fig. L).
- 17 Reinstall bodywork, fuel tank and seat.