

# Q101.002

## 1992~2008 Honda 300EX

### Stage 1&2

#### Stage 1

For mildly tuned machines using the stock airbox with stock or aftermarket filter. May also be used with a good aftermarket exhaust system.

K&N Filter # HA-3094.

#### Stage 2

For mildly tuned machines using the stock airbox with airbox lid removed, using stock or aftermarket filter. Should also be used with a good aftermarket exhaust system. K&N Filter # HA-3094

<b><i>Parts List</i></b>		
1	Main Jet	DJ106
1	Main Jet	DJ110
1	Main Jet	DJ114
1	Main Jet	DJ116
1	Main Jet	DJ118
1	Main Jet	DJ120
1	Main Jet	DJ124
1	Main Jet	DJ128
1	Main Jet Adapter	DJA001
1	Fuel Needle	DNO140
1	Adjusting Washer	DW0001
1	E-Clip	DE0001

## STAGE ONE INSTRUCTIONS

1. Remove top carb plate. Remove the slide lift arm screw and the two needle plate screws. Flip the linkage forward and remove the slide (Fig. A).
2. Install Dynojet needle on groove# 4 for applications below 5000 feet, groove #3 for above 5000 feet, using all stock spacers. Install the Dynojet washer above the E-clip.
3. Remove stock main jet. Replace with the Dynojet Main Jet Adapter (DJA001). Screw the Dynojet main provided into the Main Jet Adapter. If you are running the stock exhaust use the DJ114 below 3000 feet, DJ110 from 3000 to 6000 feet and DJ106 above 6000Feet. If you are running an aftermarket exhaust, use the DJ118 below 3000 feet, DJ114 from 3000 to 6000 feet and DJ110 above 6000 feet. Be sure that the jet you are changing is the main jet.
4. Locate the Fuel Mixture Screw. Using a flat blade screwdriver, turn the mixture screw clockwise until it seats, then turn out 3 turns below 5000 feet or 2 1/2 above 5000 feet.

## STAGE TWO INSTRUCTIONS

1. Remove the air box lid.
2. Remove top carb plate. Remove the slide lift arm screw and the two needle plate screws. Flip the linkage forward and remove the slide (Fig. A).
3. Install Dynojet needle on groove# 4 for applications below 5000 feet, groove# 3 for above 5000 feet, using all stock spacers. Install the Dynojet washer above the E-clip.
4. Remove stock main jet. Replace with the Dynojet Main Jet Adapter (DJA001). Screw the Dynojet main provided into the Main Jet Adapter. If you are running the stock exhaust use the DJ124 below 3000 feet, DJ120 from 3000 to 6000 feet and DJ116 above 6000Feet. If you are running an aftermarket exhaust, use the DJ128 below 3000 feet, DJ124 from 3000 to 6000 feet and DJ120 above 6000 feet. Be sure that the jet you are changing is the main jet.
5. Locate the Fuel Mixture Screw (Fig.B). Using a flat blade screwdriver, turn the mixture screw clockwise until it seats, then turn out 3 turns below 5000 feet or 2 1/2 above 5000 feet.

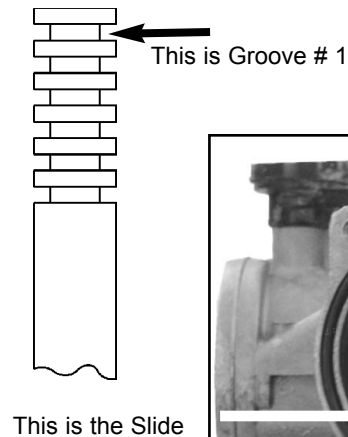

Fig.A

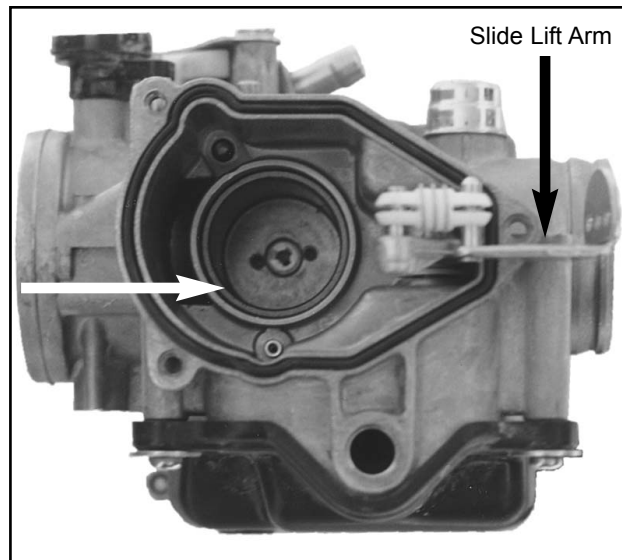

Fig.B

