

**Q402.001**  
**1994-95 Yamaha YFM350**  
**Wolverine**  
**STAGE 1**

*For mildly tuned machines using the stock airbox, with stock or aftermarket filter. May also be used with a good aftermarket exhaust system. K&N Filter# YA-4350.*

PARTS LIST		
1	Main Jet	DJ112
1	Main Jet	DJ114
1	Main Jet	DJ116
1	Main Jet	DJ118
1	Main Jet	DJ120
1	Main Jet	DJ122
1	Fuel Needle	DNO180
1	Adjusting Washer	DW0001
1	E-Clip	DE0001

## STAGE ONE INSTRUCTIONS

1. Remove top carb plate. Remove the slide lift arm screw and the two needle plate screws. Flip the linkage forward and remove the slide (Fig. A).
2. Install Dynojet needle on groove#3 for applications below 5000 feet, groove #2 for above 5000 feet, using all stock spacers. Install the Dynojet washer above the E-clip.
3. Remove stock main jet and replace with Dynojet main provided. If you are running the stock exhaust use the DJ120 below 3000 feet, DJ116 from 3000 to 6000 feet and DJ112 above 6000 feet. If you are running an aftermarket exhaust, use the DJ122 below 3000 feet, DJ118 from 3000 to 6000 feet and DJ114 above 6000 feet. Be sure that the jet you are changing is the main jet.
4. Locate the Fuel Mixture Screw. Using a flat blade screwdriver, turn the mixture screw clockwise until it seats, then turn out 2 turns below 5000 feet or 1 1/2 above 5000 feet.

**NOTE: If you have a bike with serial number 4KB-000101 ~ 002802, you must have the carburetor update installed prior to installing this kit. Your local Yamaha dealer will have this update on file as Bulletin MF94-004.**

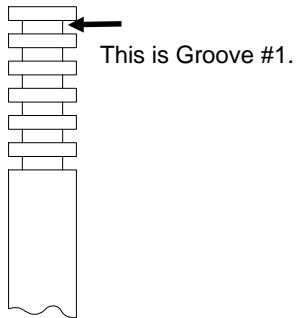

Fig. A

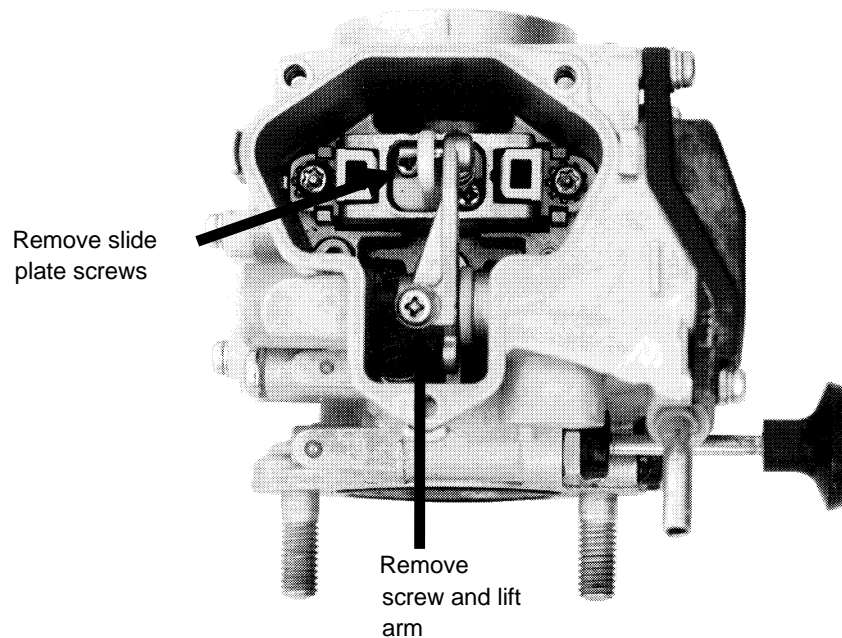

Fig.B

