

[POWER COMMANDER V]

2011-2015 KTM RC8

Installation Instructions



PARTS LIST

- 1 Power Commander
- 1 USB Cable
- 1 Installation Guide
- 2 Power Commander Decals
- 2 Dynojet Decals
- 2 Velcro strips
- 1 Alcohol swab

THE IGNITION MUST BE TURNED OFF BEFORE INSTALLATION!

THE LATEST POWER COMMANDER SOFTWARE AND MAP FILES CAN BE DOWNLOADED FROM OUR WEB SITE AT:
www.powercommander.com

PLEASE READ ALL DIRECTIONS BEFORE STARTING INSTALLATION

Dynojet

2191 Mendenhall Drive North Las Vegas, NV 89081 (800) 992-4993 www.powercommander.com

POWER COMMANDER V INPUT ACCESSORY GUIDE

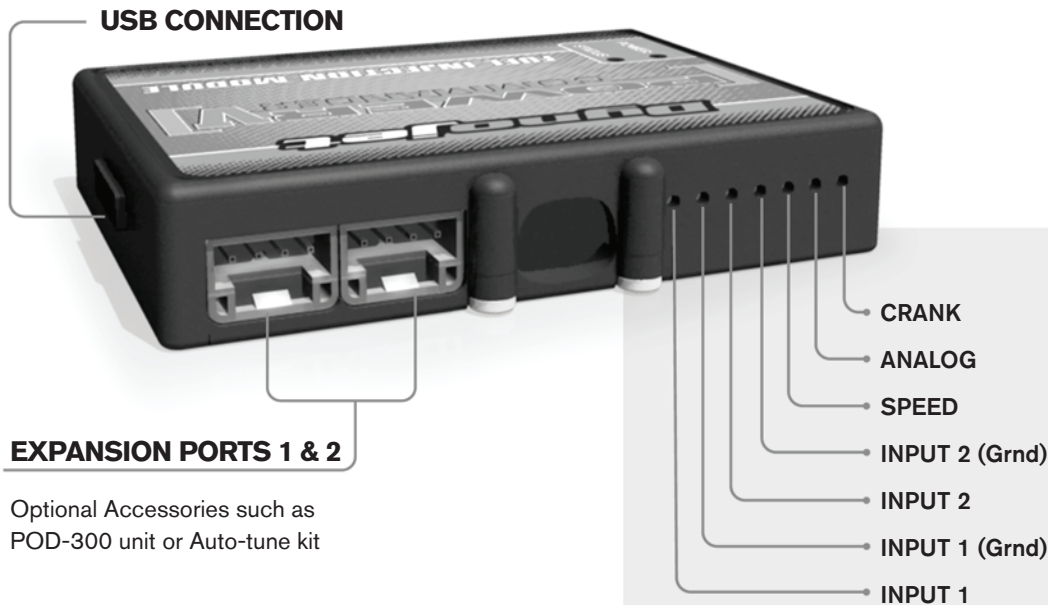

Wire connections:

To input wires into the PCV first remove the rubber plug on the backside of the unit and loosen the screw for the corresponding input. Using a 22-24 gauge wire strip about 10mm from its end. Push the wire into the hole of the PCV until it stops and then tighten the screw. Make sure to reinstall the rubber plug.

NOTE: If you tin the wires with solder it will make inserting them easier.

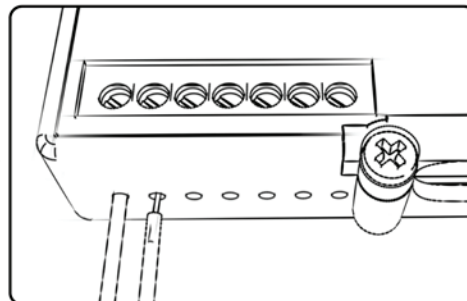

ACCESSORY INPUTS

Map -

(Input 1 or 2) The PCV has the ability to hold 2 different base maps. You can switch on the fly between these two base maps when you hook up a switch to the MAP inputs. You can use any open/close type switch. The polarity of the wires is not important. When using the Autotune kit one position will hold a base map and the other position will let you activate the learning mode. When the switch is "CLOSED" Autotune will be activated. (Set to Switch Input #1 by default.)

Shifter-

(Input 1 or 2) These inputs are for use with the Dynojet quickshifter. Insert the wires from the Dynojet quickshifter into the SHIFTER inputs. The polarity of the wires is not important. (Set to Switch Input #2 by default.)

Speed-

If your application has a speed sensor then you can tap into the signal side of the sensor and run a wire into this input. This will allow you to calculate gear position in the Control Center Software. Once gear position is setup you can alter your map based on gear position and setup gear dependent kill times when using a quickshifter.

Analog-

This input is for a 0-5v signal such as engine temp, boost, etc. Once this input is established you can alter your fuel curve based on this input in the control center software.

Crank-

Do **NOT** connect anything to this port unless instructed to do so by Dynojet. It is used to transfer crank trigger data from one module to another.

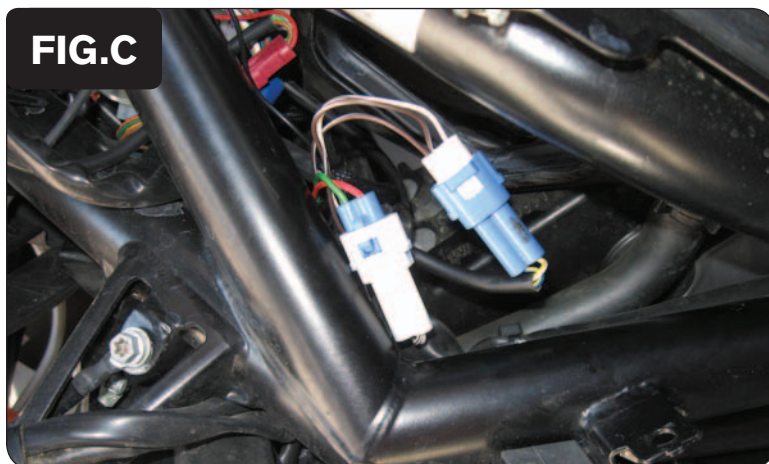
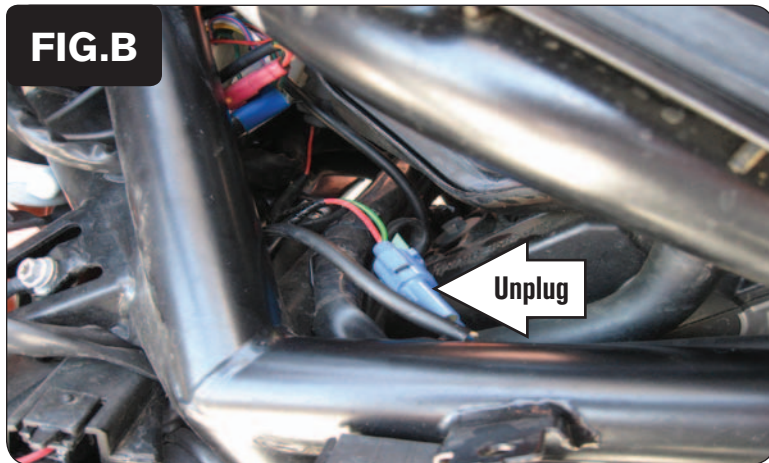
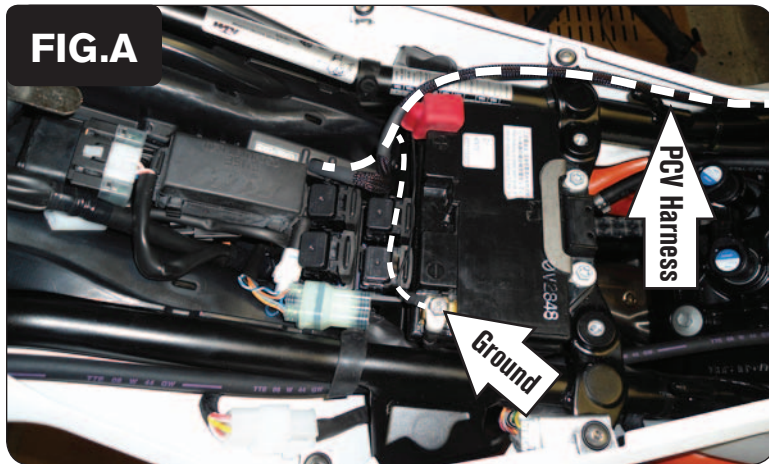

- 1 Remove the seat and both side fairings.
- 2 Remove the fuel tank.
- 3 Lay the PCV next to the battery and route the PCV harness along the frame on the left side and forward towards the front of the engine.
- 4 Attach the PCV ground wire with the small ring lug to the negative (-) terminal of the bike's battery (Fig. A).

- 5 Locate the stock Crank Position Sensor connectors on the left side of the motorcycle. Unplug this connection (Fig. B).

This is a BLUE 2-pin connector pair. On one of the connectors it has a RED wire and a GREEN wire.

- 6 Plug the PCV wiring harness in-line of the stock Crank Position Sensor connectors (Fig. C).
- 7 Route the PCV harness over to the right side of the motorcycle going in front of the air box.

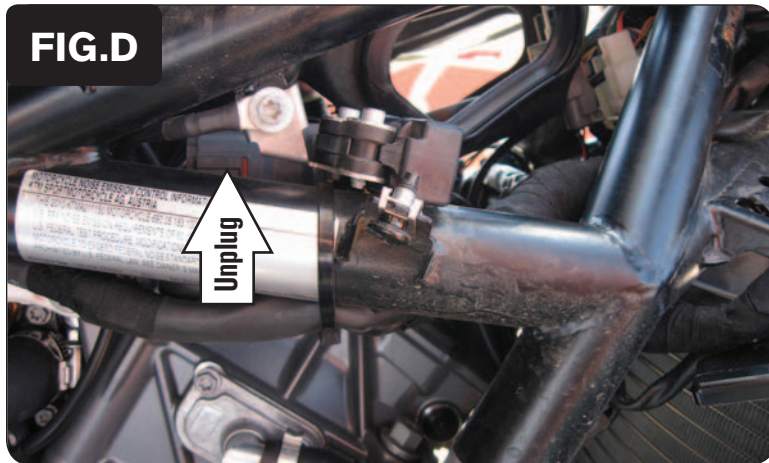

- 8 Locate the sub-harness connectors from the throttle bodies on the right side of the motorcycle. Unplug this connection (Fig. D).

This is a GREY 16-pin connector pair located between the frame and the air box near the tip over sensor.



- 9 Route the PCV harness to the inside of the frame which may require you to move the MAP sensor.
- 10 Plug the PCV wiring harness in-line of the stock throttle body sub-harness connectors (Fig. E).
- 11 Reinstall the fuel tank, the removed bodywork, and the seat.