

# [POWER COMMANDER V]

## **2015-2016 Husqvarna FE501**

### Installation Instructions



#### **PARTS LIST**

- 1 Power Commander
- 1 USB Cable
- 1 Installation Guide
- 2 Power Commander Decals
- 2 Dynojet Decals
- 2 Velcro strips
- 1 Alcohol swab

**THE IGNITION MUST BE TURNED  
OFF BEFORE INSTALLATION!**

THE LATEST POWER COMMANDER  
SOFTWARE AND MAP FILES CAN BE  
DOWNLOADED FROM OUR WEB SITE AT:  
[www.powercommander.com](http://www.powercommander.com)

**PLEASE READ ALL DIRECTIONS BEFORE STARTING INSTALLATION**

**Dynojet**

2191 Mendenhall Drive North Las Vegas, NV 89081 (800) 992-4993 [www.powercommander.com](http://www.powercommander.com)

# POWER COMMANDER V INPUT ACCESSORY GUIDE

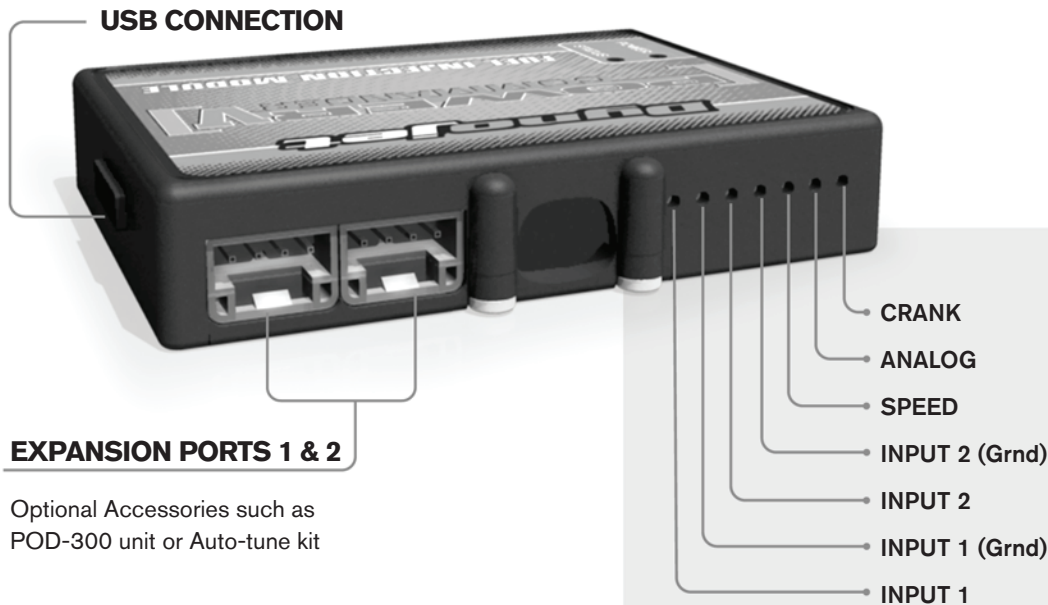

## Wire connections:

To input wires into the PCV first remove the rubber plug on the backside of the unit and loosen the screw for the corresponding input. Using a 22-24 gauge wire strip about 10mm from its end. Push the wire into the hole of the PCV until it stops and then tighten the screw. Make sure to reinstall the rubber plug.

NOTE: If you tin the wires with solder it will make inserting them easier.

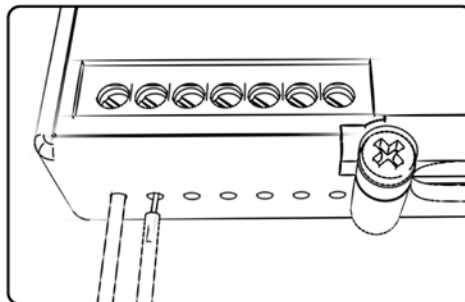

## ACCESSORY INPUTS

### Map -

(Input 1 or 2) The PCV has the ability to hold 2 different base maps. You can switch on the fly between these two base maps when you hook up a switch to the MAP inputs. You can use any open/close type switch. The polarity of the wires is not important. When using the Autotune kit one position will hold a base map and the other position will let you activate the learning mode. When the switch is "CLOSED" Autotune will be activated. (Set to Switch Input #1 by default.)

### Shifter-

(Input 1 or 2) These inputs are for use with the Dynojet quickshifter. Insert the wires from the Dynojet quickshifter into the SHIFTER inputs. The polarity of the wires is not important. (Set to Switch Input #2 by default.)

### Speed-

If your application has a speed sensor then you can tap into the signal side of the sensor and run a wire into this input. This will allow you to calculate gear position in the Control Center Software. Once gear position is setup you can alter your map based on gear position and setup gear dependent kill times when using a quickshifter.

### Analog-

This input is for a 0-5v signal such as engine temp, boost, etc. Once this input is established you can alter your fuel curve based on this input in the control center software.

### Crank-

Do **NOT** connect anything to this port unless instructed to do so by Dynojet. It is used to transfer crank trigger data from one module to another.

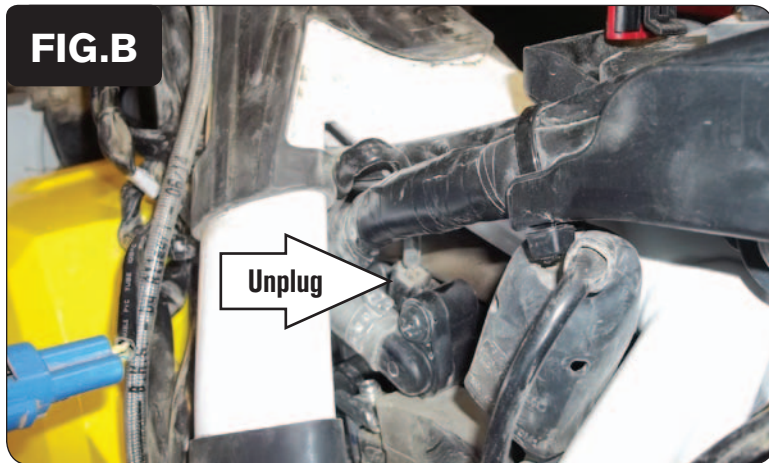
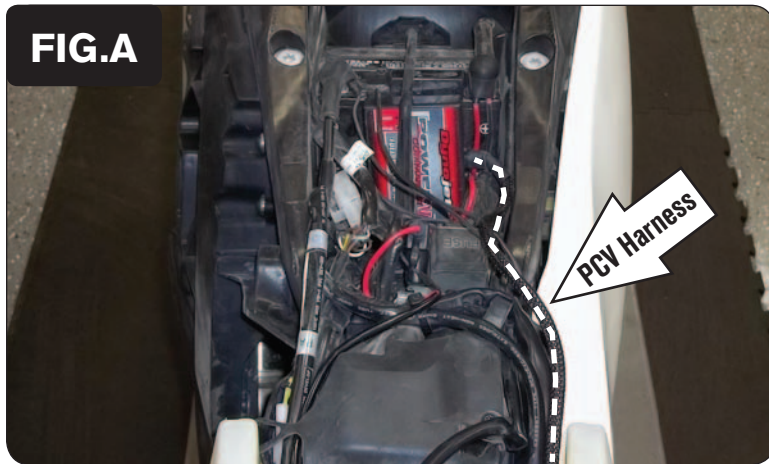

- 1 Remove the seat.
- 2 Remove the radiator shrouds on both sides and remove the fuel tank.
- 3 Using the supplied Velcro and/or the stock rubber strap, secure the PCV module to the front of the battery (Fig. A).

*Clean both surfaces with the supplied alcohol swab prior to applying the Velcro.*

- 4 Route the PCV wiring harness forward along the left side frame rail.

- 5 Unplug the Fuel Injector at the top of the throttle body (Fig. B).

- 6 Route the PCV wiring harness under the frame and out towards the left side of the engine.
- 7 Plug the pair of PCV leads with ORANGE colored wires in-line of the Fuel Injector and the stock wiring harness (Fig. C).



- 8 Unplug the Throttle Position Sensor located on the left side of the throttle body (Fig. D).

*The TPS will be covered by a BLACK rubber boot.*

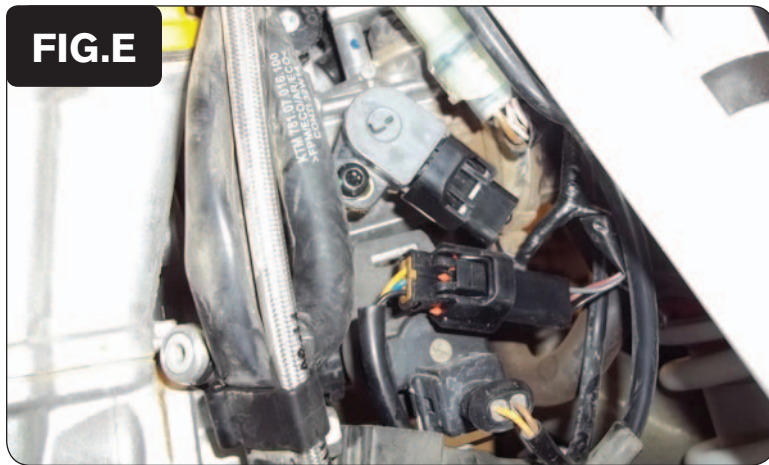

- 9 Plug the pair of 3-pin PCV connectors in-line of the TPS and the stock wiring harness (Fig. E).



- 10 Unplug the bike's Crank Position Sensor connectors (Fig. F).

*This is a BLUE 2-pin connector pair located on the left side of the engine.*



- 11 Plug the pair of WHITE 2-pin PCV connectors with BROWN colored wires in-line of the stock CPS connectors (Fig. G).

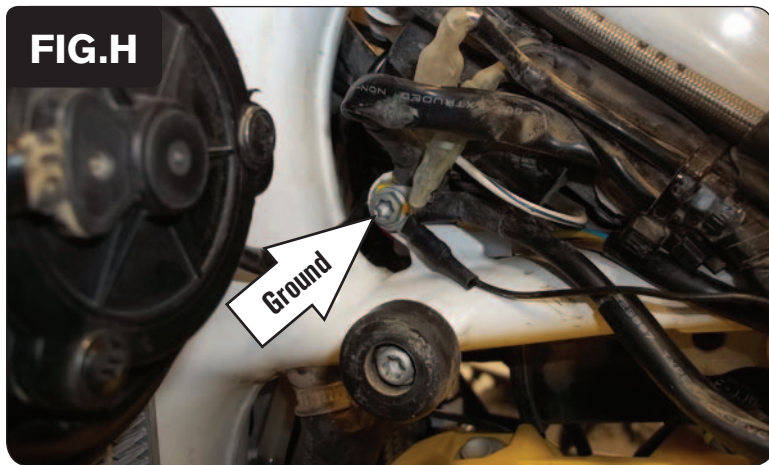

- 12 Secure the PCV ground wire with the small ring lug to the stock common ground on the left side of the frame directly above the engine (Fig. H).
- 13 Reinstall the fuel tank, the radiator shrouds, and the seat.